

# Hydraulic Flanges

SAE J 518 C & ISO 6164

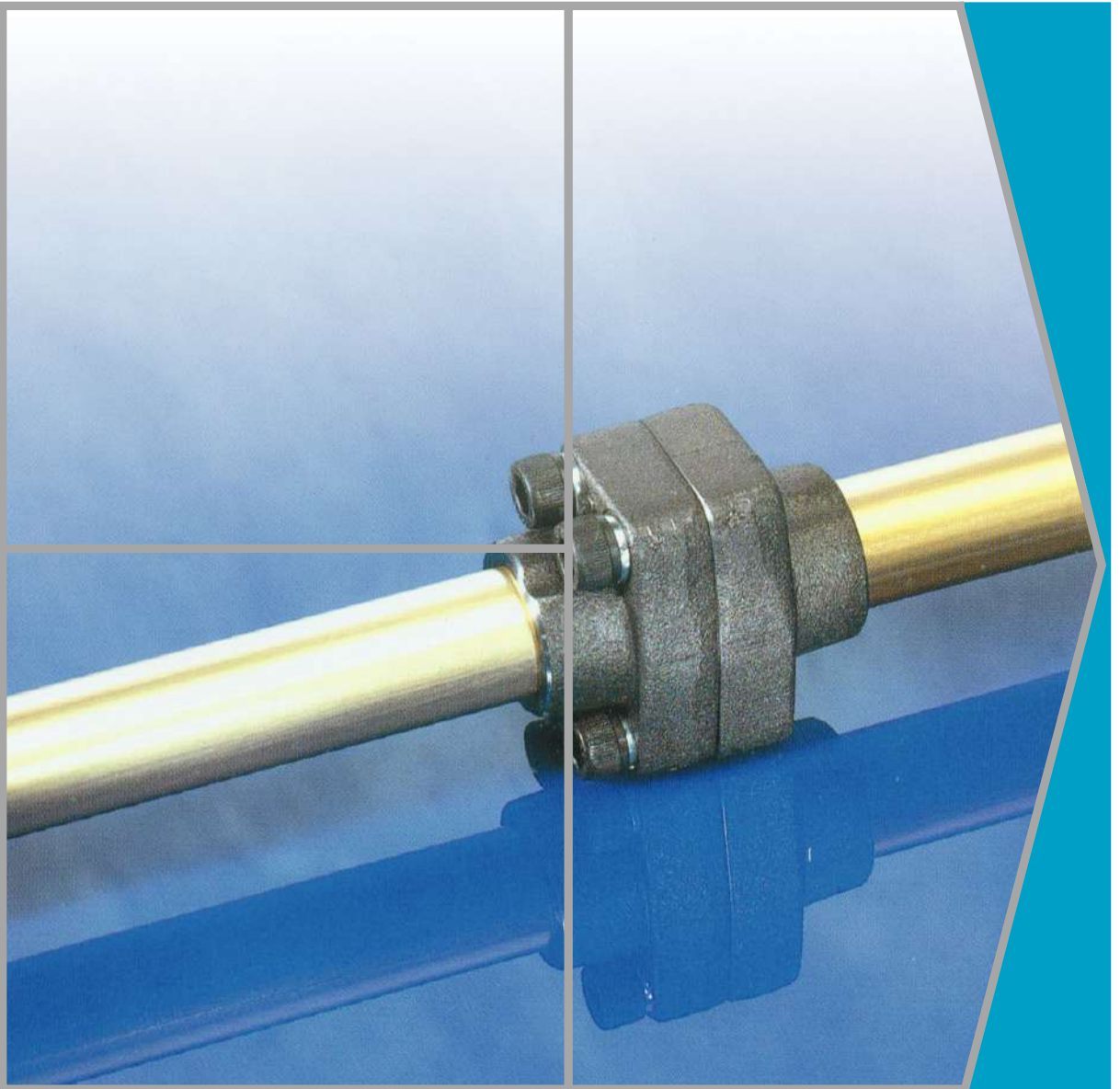

Catalog No. H - 2002SF  
Jun. 2002



하이록코리아주식회사  
HY-LOK CORPORATION



## SAE-Flanges (ISO 6162)

SAE-split flange halves	SAFH	1
SAE-split flange halves - flat	SAHF	2
SAE-flange clamp	SAVH	3
SAE-flange clamp with tapped holes	SAVFG	4
SAE-flange clamp - flat	SAEFGA	5
SAE-flange clamp with tapped - flat	SAEFGB	6
SAE-pipe threaded flange	SAAFS	7
SAE-pipe threaded flange - companion	SAGFS	8
SAE-NPT threaded flange	SAAFS-N	9
SAE-NPT threaded flange-companion	SAGFS-N	10
SAE-UN-threaded flange	SAAFS-U	11
SAE-DIN 2353 connection 3901/3902	SAAFG	12
SAE-DIN 2353 connection 3901/3902	SASFCE	13/14
SAE-JIC fared connection flange	SAAFG-J	15
SAE-socket weld flange	SAAFS-SW	16
SAE-socket weld flange companion	SAGFS-SW	17
SAE-socket weld-coupling	SADFS-SW	18
SAE-socket weld flange 500 psi	SA AFC-SW	19
SAE-socket weld flange 500 psi - companion	SAGFC-SW	20
SAE-socket weld flange 500 psi - coupling	SADFC-SW	21
SAE-weld on flange	SAAFS-BW	22
SAE-weld on flange - companion	SAGFS-BW	23
SAE-weld on flange - pipe schedule 40	SAAFS-BW	24
SAE-weld on flange - pipe schedule 40 - companion	SAGFS-BW	25
SAE-weld in flange - metric tubes	SAAFS-M	26
SAE-weld in flange - metric tubes - companion	SAGFS-M	27
SAE-welding head	SASFH-BW	28
SAE-welding head - coupling	SADFH-BW	29
SAE-welding neck hub	SAEWNA	30
SAE-welding neck - coupling	SAEWNC	31
SAE-weld of coupling	SADFS-BW	32
SAE-closed flange	SA AFC	33
SAE-closed flange companion	SAAFG	34
SAE-closed flange plug	SABSO/BS	35
SAE-flange head	SAFT	36
SAE-locking sheet	SAAP	37
SAE-adaptor sheet	SAEP	38
SAE-adaptor flange with test-point	SAAGL	39
SAE-adaptor 90° - welded	SAAG	40
SAE-T-connection - welded	SAT	41
SAE-90° L-block	SAL-GD	42

## Square flange connections(ISO 6164)

SAE-90° L-block - companion	SAL-BL	43
SAE-90° L-reduction	SARED-GD	44
SAE-T-block	SAT-GD	45
SAE-T-Block - companion	SAT-BL	46
Butt welding centering flange - PN - 160 - ISO 6164-1	SAVKA / VKK 16	47
Butt welding centering flange - PN - 250 - ISO 6164-1	SAVKA / VKK 25	48
Butt welding centering flange - PN - 315 - ISO 6164-2	SAVKA / VKK 35	49
Butt welding centering flange - PN - 400 - ISO 6164-2	SAVKA / VKK 40	50
T-connection	SAVKV	51
Cetop-square flange	SACET	52
Cetop-square flange coupling	SADCET	53
Cetop-flange plug	SABS	54

## Technical Informations

### Used standards

Our flanges are based on the following standards :

SAE-flanges    standard : SAE J518 C, ISO 6162

4-bolt square flanges standard : ISO / DIS 6164

Cetop-flanges    standard : CETOP RP 63H, ISO 6164

### Pressure rates

The maximum recommendaed working pressure is indicated at each single article.

Befor using a part, please take notice of the pressure indications.

All pressure indications are based on a working temperature from -20° celsius up to +90° celsius. Outside of this temperature range the pyhsical properties of the used material is impacted and the maximum recommended working pressure is reduced.

The indicated working pressure refer only on the flange itself.

For the used tubes, fittings and connections the pressure indications of the specific manufacture is the determinative factor.

## Flange tube connections

For tube connections with our flanges, we recommend tubes which follow the following standard.

-seamless precision steel pipes according DIN2391, pipes according to ANSI/ASME B36.10M & B36.19M

For the flange sizes and pressure rates, we recommend the following tube dimensions

Size	Tubes to DIN 2391					Pipes to ANSI/ASME B36.10M & B36.19M			
	Series					Series			
	100bar	160bar	250bar	315bar	400bar	160bar(40S)	250bar(80S)	350bar(160S)	400bar(XXS)
½"	15 x 1 18 x 1	18 x 1.5	16 x 2 20 x 2.5	16 x 2.5 20 x 3	16 x 3 20 x 3.5	21.3 x 2.7	21.3 x 3.7	21.3 x 4.7	21.3 x 7.5
¾"			25 x 3	25 x 3.5	25 x 4	26.7 x 2.9	26.7 x 3.9	26.7 x 5.5	26.7 x 7.8
1"	28 x 2		28 x 3 30 x 4	30 x 5	30 x 6	33.4 x 3.4	33.4 x 4.5	33.4 x 6.4	33.7 x 9.1
1 ¼"	35 x 2		35 x 4 38 x 5	38 x 6	38 x 7	42.2 x 3.6	42.2 x 4.9	42.2 x 6.4	42.4 x 9.7
1 ½"	42 x 3		42 x 5 50 x 6	50 x 8	50 x 9	48.3 x 3.7	48.3 x 5.1	48.3 x 7.1	48.3 x 10.2
2"				65 x 8	65 x 10	60.3 x 3.9	60.3 x 5.5	60.3 x 8.7	60.3 x 11.1
2 ½"				80 x 10	80 x 12.5	73.0 x 3.9	73.0 x 7.0	73.0 x 9.5	73.0 x 14.0
3"						88.9 x 5.2	88.9 x 7.6	88.9 x 11.1	88.9 x 15.2
3 ½"						101.5 x 5.5	101.5 x 8.1	101.5 x 12.7	
4"						114.3 x 5.7	114.3 x 8.6	114.3 x 13.5	114.3 x 17.1
5"						141.3 x 6.6	141.3 x 9.5	141.3 x 15.9	141.3 x 19.0



## Used materials

For every single product group the used material is being indicated.

If several materials are shown, it is on the estimation of the manufacturer what material is used.

## Surface protection

As far as there is no special instruction on a product range all flanges are being delivered in blank steel with protection fluid against rust.

## Flange kits

As far as required all flange connections can be supplied with bolt set and O-ring.

The designation for order is shown on every product group as a sample.

Used bolts		
SAE flanges	metric bolts	DIN 912-8.8 (ISO 4762-8.8) or DIN 912-10.9 (ISO 4762-10.9)*1)
	UNC bolts :	ASA B 18.3
Square flanges	metric bolts	DIN 931/9 34-8.8 (ISO 4014/4017-8.8) or DIN 931/9 34-10.9 (ISO 4014/4017-10.9)*1)
Cetop flanges	metric bolts	DIN 931/9 34-8.8 (ISO 4014/4017-8.9) or DIN 931/9 34-10.9 (ISO 4014/4017-10.9)*1)
*1) bolts with grade 10.9 are to be used, when the material for the flanges is high tempered!		

## Sealings

All flange connection in this catalogue are sealing with an O-ring. The O-rings which are supplied by us are out of the following materials.

- Buna 90 shore(standard)
- Viton 85-90 shore(option)

For all SAE flanges and Cetop flanges the O-ring dimensions are according to the following table.

When the O-rings differ from these dimensions, the specific article shows the precise dimension.

## Dimensions of o-ring for SAE-flanges, Cetop-flanges

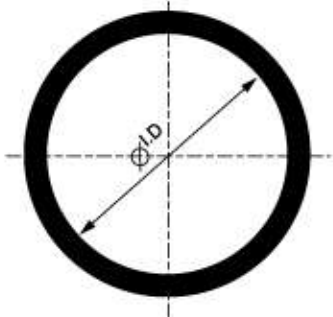
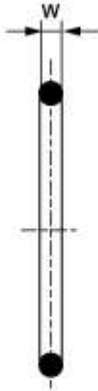
		<b>Flange size, in</b>	<b>I. D</b>	<b>W</b>
		3/8"	17.1	2.6
		1/2"	18.7	3.5
		3/4"	25.0	3.5
		1"	32.9	3.5
		1 1/4"	37.7	3.5
		1 1/2"	47.2	3.5
		2"	56.8	3.5
		2 1/2"	69.5	3.5
		3"	85.3	3.5
		3 1/2"	98.0	3.5
		4"	110.7	3.5
		5"	136.1	3.5

# SAE-split flange halves

SAE - split flange halves

## SAFH

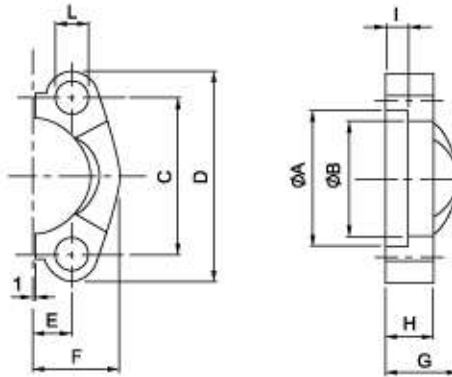

Maximum recommended working pressure kg/cm <sup>2</sup>	Nominal flange size, in	Type	Dimensions										screws		Weight kg		
			A	B	C	D	E	F	G	H	I	L	metr.	unc			
		<b>Standard Pressure</b>															
350	½"	SAFH 308	30.96	24.26	38.10	54	8.74	22.8	19	13	6.22	9.0	M 8 x 25	⅜ x 1½	0.07		
350	¾"	SAFH 312	38.89	32.13	47.63	65	11.13	25.9	22	14	6.22	11.0	M 10 x 30	⅜ x 1½	0.09		
350	1"	SAFH 316	45.24	38.48	52.37	70	13.08	29.2	24	16	7.49	11.0	M 10 x 30	⅜ x 1½	0.11		
280	1½"	SAFH 320	51.59	43.69	58.72	79	15.09	36.3	22	16	7.49	11.5	M 10 x 35	⅜ x 1½	0.15		
210	1½"	SAFH 324	61.09	50.80	69.85	94	17.86	41.1	25	16	7.49	13.5	M 12 x 35	½ x 1½	0.23		
210	2"	SAFH 332	72.24	62.74	77.77	102	21.44	48.2	26	16	9.02	13.5	M 12 x 35	½ x 1½	0.25		
175	2½"	SAFH 340	84.94	74.93	80.90	114	25.40	54.1	38	19	9.02	13.5	M 12 x 40	½ x 1½	0.37		
140	3"	SAFH 348	102.39	90.93	106.38	135	30.96	65.3	41	22	9.02	17.0	M 16 x 45	⅝ x 2	0.65		
35	3½"	SAFH 356	115.10	102.36	120.65	152	34.92	69.5	28	22	10.72	17.0	M 16 x 45	⅝ x 2	0.75		
35	4"	SAFH 364	127.79	115.06	130.18	162	98.88	76.0	35	25	10.72	17.0	M 16 x 50	⅝ x 2	0.84		
35	5"	SAFH 380	153.19	140.46	152.40	184	46.04	90.0	41	28	10.72	17.0	M 16 x 50	⅝ x 2	1.25		
		<b>High Pressure</b>															
420	½"	SAFH 608	32.54	24.64	40.49	56	9.12	23.6	22	16	7.24	9.0	M 8 x 30	⅜ x 1½	0.08		
420	¾"	SAFH 612	42.06	32.51	50.80	71	11.91	30.0	28	19	8.26	11.0	M 10 x 35	⅜ x 1½	0.18		
420	1"	SAFH 616	48.41	38.86	57.17	81	3.89	34.8	33	24	9.02	12.5	M 12 x 45	⅜ x 1½	0.27		
420	1½"	SAFH 620	54.76	44.45	66.68	95	15.88	38.6	38	27	9.78	14.5	M 14 x 50	½ x 1½	0.40		
420	1½"	SAFH 624	64.29	51.56	79.38	113	18.26	47.5	43	30	12.07	17.0	M 16 x 55	⅝ x 2	0.68		
420	2"	SAFH 632	80.16	67.56	96.82	133	22.23	56.9	52	37	12.07	21.0	M 20 x 65	⅝ x 2½	1.05		

# SAE J 518 C 61/62 Flanges

SAE - split flanges halves - flat

## SAHF

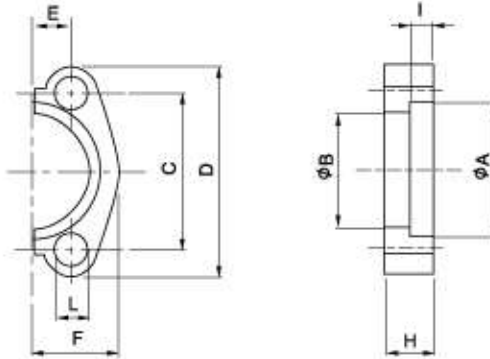

Maximum recommended working pressure kg/cm <sup>2</sup>	Nominal flange size, in	Type	Dimensions								Screws		Weight kg	
			A	B	C	D	E	F	H	L	metr.	unc		
		<b>Standard Pressure</b>												
350	½"	SAHF 308	30.96	24.26	38.10	54	8.74	22.8	13	9.0	M 8x25	⅝" x 1½"	0.06	
350	¾"	SAHF 312	38.89	32.13	47.63	65	11.13	25.9	14	11.0	M 10x30	⅝" x 1½"	0.07	
350	1"	SAHF 316	45.24	38.48	52.37	70	13.08	29.2	16	11.0	M 10x30	⅝" x 1½"	0.10	
280	1¼"	SAHF 320	51.59	43.69	58.72	79	15.09	36.6	16	11.5	M 10x35	⅝" x 1½"	0.15	
210	1½"	SAHF 324	61.09	50.80	69.85	94	17.86	41.1	16	13.5	M 12x35	⅝" x 1½"	0.18	
210	2"	SAHF 332	72.24	62.74	77.77	102	21.44	48.2	16	13.5	M 12x35	⅝" x 1½"	0.22	
		<b>High Pressure</b>												
420	½"	SAHF 608	32.54	24.64	40.49	56	9.12	23.6	16	9.0	M 8x30	⅝" x 1½"	0.08	
420	¾"	SAHF 612	42.06	32.51	50.80	71	11.91	30.0	20	11.0	M 10x35	⅝" x 1½"	0.16	
420	1"	SAHF 616	48.41	38.86	57.15	81	13.89	34.8	25	12.5	M 12x45	⅝" x 1½"	0.25	
420	1¼"	SAHF 620	54.76	44.45	66.68	95	15.88	38.6	27	14.5	M 14x45	⅝" x 1½"	0.34	
420	1½"	SAHF 624	64.29	51.56	79.38	113	19.26	47.5	30	17.0	M 16x50	⅝" x 2"	0.55	
420	2"	SAHF 632	80.16	67.56	96.82	133	22.23	56.9	37	21.0	M 20x65	⅝" x 2½"	1.02	
420	2½"	SAHF 640	108.90	90.00	123.80	180	29.40	75.08	45	26.0	M 24x75	-	2.05	
420	3"	SAHF 648	132.50	115.00	152.40	215	35.80	99.08	55	31.0	M 30x90	-	4.30	



# SAE J 518 C 61/62 Flanges

SAE - flange clamp

**SAVH**

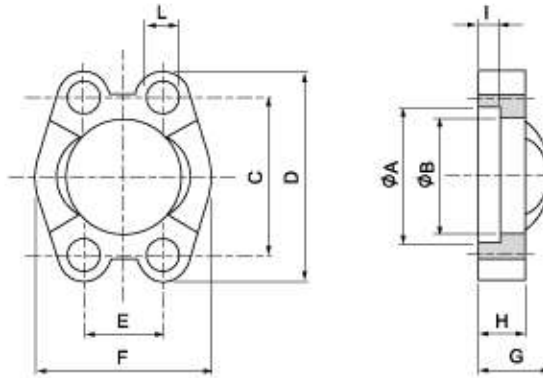

Maximum recommended working pressure kg/cm <sup>2</sup>	Nominal flange size, in	Type	Dimensions										Screws		Weight kg		
			A	B	C	D	E	F	G	H	I	L	metr.	unc			
<b>Standard Pressure</b>																	
350	½"	SAVF 308	30.96	24.26	38.10	54	17.48	45.6	19	13	6.22	9.0	M 8 x 25	⅝ x 1½	0.15		
350	¾"	SAVF 312	38.89	32.13	47.63	65	22.23	51.8	22	14	6.22	11.0	M 10 x 30	⅝ x 1½	0.17		
350	1"	SAVF 316	45.24	38.48	52.37	70	26.19	58.4	24	16	7.49	11.0	M 10 x 35	⅝ x 1½	0.22		
420	1"	SAVF 316-62	45.24	38.48	52.37	71	26.19	60.0	26	26	7.49	11.0	M 10 x 45	⅝ x 1½	0.43		
280	1¼"	SAVF 320	51.59	43.69	58.72	79	30.18	72.6	22	16	7.49	11.5	M 12 x 35	⅝ x 1½	0.30		
420	1¼"	SAVF 320-62	51.59	43.69	58.72	80	30.18	73.0	33	24	7.49	13.5	M 12 x 45	⅝ x 1½	0.64		
210	1½"	SAVF 324	61.09	50.80	69.85	94	35.71	82.2	25	16	7.49	13.5	M 12 x 35	⅝ x 1½	0.45		
420	1½"	SAVF 324-62	61.09	50.80	69.85	95	35.71	83.0	37	27	7.49	13.5	M 12 x 50	⅝ x 1½	0.96		
210	2"	SAVF 332	72.24	62.74	77.77	102	42.88	96.4	26	16	9.02	13.5	M 12 x 35	⅝ x 1½	0.50		
420	2"	SAVF 332-62	72.24	62.74	77.77	103	42.88	97.0	43	30	9.02	13.5	M 12 x 50	⅝ x 1½	1.38		
175	2½"	SAVF 340	84.94	74.93	88.90	114	50.80	108.2	38	19	9.02	13.5	M 12 x 40	⅝ x 1½	0.74		
420	2½"	SAVF 340-62	84.94	74.93	88.90	114	50.80	108.2	49	30	9.02	14.5	M 14 x 50	⅝ x 1½	1.75		
140	3"	SAVF 348	102.39	90.93	106.38	135	61.93	130.6	41	22	9.02	17.0	M 16 x 50	⅝ x 2	1.30		
35	3½"	SAVF 356	115.10	102.40	120.65	152	69.85	139.0	28	22	10.72	17.0	M 16 x 50	⅝ x 2	1.50		
35	4"	SAVF 364	127.79	115.10	130.18	162	77.77	152.0	35	25	10.72	17.0	M 16 x 50	⅝ x 2	1.65		
35	5"	SAVF 380	153.19	140.50	152.40	184	92.08	180.0	41	28	10.72	17.0	M 16 x 50	⅝ x 2	2.50		
<b>High Pressure</b>																	
420	½"	SAVF 608	32.54	24.26	40.49	56	18.24	47.2	22	16	7.24	9.0	M 8 x 30	⅝ x 1½	0.16		
420	¾"	SAVF 612	42.06	32.51	50.80	71	23.80	60.0	28	19	8.26	11.0	M 10 x 35	⅝ x 1½	0.35		
420	1"	SAVF 616	48.41	38.86	57.15	81	27.76	69.9	33	24	9.02	12.5	M 12 x 45	⅝ x 1½	0.53		
420	1¼"	SAVF 620	54.76	44.45	66.68	95	31.75	77.2	38	27	9.78	14.5	M 14 x 50	⅝ x 1½	0.80		
420	1½"	SAVF 624	64.29	51.56	79.38	113	36.50	95.0	43	30	12.07	17.0	M 16 x 55	⅝ x 2	1.35		
420	2"	SAVF 632	80.16	67.56	96.82	133	44.45	113.8	52	37	12.07	21.0	M 20 x 65	⅝ x 2½	2.10		
420	2½"	SAVF 640	108.90	90.00	123.80	180	58.80	190.2	45	45	20.50	26.0	M 24 x 75	-	4.10		
420	3"	SAVF 648	132.50	115.00	152.40	215	71.60	198.2	55	55	25.50	31.0	M 30 x 90	-	8.60		



# SAE J 518 C 61/62 Flanges

SAE - flange clamp with tapped holes

**SAVFG**

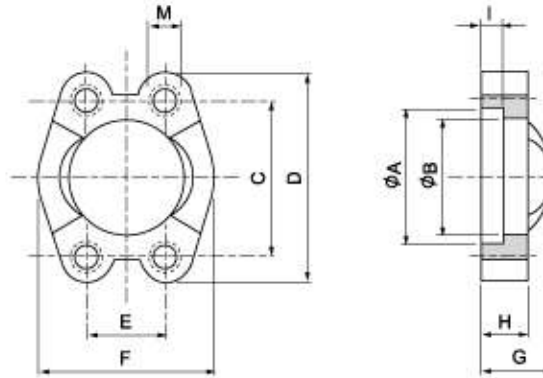

Maximum recommended working pressure kg/cm <sup>2</sup>	Nominal flange size, in	Type	Dimensions										Weight kg	
			A	B	C	D	E	F	G	H	I	M		
		<b>Standard Pressure</b>												
350	½"	SAVFG 308	30.96	24.26	38.10	54	17.48	45.6	19	13	6.22	M 8	0.15	
350	¾"	SAVFG 312	38.89	32.13	47.63	65	22.23	51.8	22	14	6.22	M 10	0.17	
350	1"	SAVFG 316	45.24	38.48	52.37	70	26.19	58.4	24	16	7.49	M 10	0.22	
280	1½"	SAVFG 320	51.59	43.69	58.72	79	30.18	72.6	22	16	7.49	M 10	0.30	
210	1½"	SAVFG 324	61.09	50.80	69.85	94	35.71	82.2	25	16	7.49	M 12	0.45	
210	2"	SAVFG 332	72.24	62.74	77.77	102	42.88	96.4	26	16	9.02	M 12	0.50	
175	2½"	SAVFG 340	84.94	74.93	88.90	114	50.80	108.2	38	19	9.02	M 12	0.74	
140	3"	SAVFG 348	102.39	90.93	106.38	135	61.93	130.6	41	22	9.02	M 16	1.30	
35	3½"	SAVFG 356	115.10	102.36	120.65	152	69.85	139.0	28	22	10.72	M 16	1.50	
35	4"	SAVFG 364	127.79	115.06	130.18	162	77.77	152.0	35	25	10.72	M 16	1.65	
35	5"	SAVFG 380	153.19	140.46	152.40	184	92.08	180.0	41	28	10.72	M 16	2.50	
		<b>High Pressure</b>												
420	½"	SAVFG 608	32.54	24.26	40.49	56	18.24	47.2	22	16	7.24	M 8	0.16	
420	¾"	SAVFG 612	42.06	32.51	50.80	71	23.80	60.0	28	19	8.26	M 10	0.35	
420	1"	SAVFG 616	48.41	38.86	57.15	81	27.76	69.9	33	24	9.02	M 12	0.53	
420	1½"	SAVFG 620	54.76	44.45	66.68	95	31.75	77.2	38	27	9.78	M 14	0.80	
420	1½"	SAVFG 624	64.29	51.56	79.38	113	36.50	95.0	43	30	12.07	M 16	1.35	
420	2"	SAVFG 632	80.16	67.56	96.82	133	44.45	113.8	52	37	12.07	M 20	2.10	
420	2½"	SAVFG 640	108.90	90.00	123.80	180	58.80	190.2	45	45	20.50	M 24	4.10	
420	3"	SAVFG 648	132.50	115.00	152.40	215	71.60	198.16	55	55	25.50	M 30	8.60	

# SAE J 518 C 61/62 Flanges

SAE - flange clamp - flat

## SAEFGA

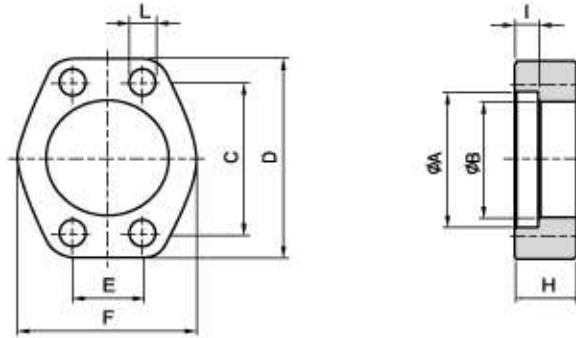

Maximum recommended working pressure kg/cm <sup>2</sup>	Nominal flange size, in	Type	Dimensions									Screws		Weight kg		
			A	B	C	D	E	F	H	I	L	Metr.	Unc			
		<b>Standard Pressure</b>														
350	½"	SAEFGA04-61	30.96	24.26	38.10	54	17.48	45.6	20	6.22	9.0	M 8 x 35	⅝ x 1½	0.18		
350	¾"	SAEFGA06-61	38.89	32.13	47.63	65	22.23	51.8	20	6.22	11.0	M 10 x 35	⅝ x 1½	0.20		
350	1"	SAEFGA08-61	45.24	38.48	52.37	70	26.19	58.4	22	7.49	11.0	M 10 x 35	⅝ x 1½	0.26		
420	1"	SAEFGA308-62	45.24	38.48	52.37	71	26.19	60.0	25	7.49	11.0	M 10 x 45	-	0.52		
280	1½"	SAEFGA10-61	51.59	43.69	58.72	79	30.18	72.6	22	7.49	11.5	M 12 x 45	⅝ x 1½	0.36		
420	1½"	SAEFGA310-62	51.59	43.69	58.72	80	30.18	73.0	30	7.49	13.5	M 12 x 50	-	0.77		
280	1½"	SAEFGA12-61	61.09	50.80	69.85	94	35.71	82.2	25	7.49	13.5	M 12 x 45	½ x 1½	0.54		
420	1½"	SAEFGA312-62	61.09	50.80	69.85	95	35.71	83.0	33	7.49	13.5	M 12 x 60	-	1.15		
280	2"	SAEFGA16-61	72.24	62.74	77.77	102	42.88	96.4	30	9.02	13.5	M 12 x 50	½ x 1½	0.60		
420	2"	SAEFGA316-62	72.24	62.74	77.77	103	42.88	97.0	38	9.02	13.5	M 12 x 70	-	1.66		
210	2½"	SAEFGA20-61	84.94	74.93	88.90	114	50.80	108.2	36	9.02	13.5	M 12 x 60	½ x 1½	0.89		
420	2½"	SAEFGA320-62	84.94	74.93	88.90	114	50.80	108.2	45	9.02	14.5	M 14 x 75	-	2.10		
210	3"	SAEFGA24-61	102.39	90.93	106.38	135	61.93	130.6	41	9.02	17.0	M 16 x 70	⅝ x 2	1.56		
160	3½"	SAEFGA28-61	115.10	102.36	120.65	152	69.85	139.0	28	10.72	17.0	M 16 x 50	⅝ x 2	1.80		
160	4"	SAEFGA32-61	127.79	115.06	130.18	162	77.77	152.0	35	10.72	17.0	M 16 x 60	⅝ x 2	1.98		
35	5"	SAEFGA40-61	153.19	140.46	152.40	184	92.08	180.0	41	10.72	17.0	M 16 x 70	⅝ x 2	3.00		
		<b>High Pressure</b>														
420	½"	SAEFGA04-62	32.54	24.26	40.49	56	18.24	47.2	22	7.24	9.0	M 8 x 35	⅝ x 1½	0.19		
420	¾"	SAEFGA06-62	42.06	32.51	50.80	71	23.80	60.0	23	8.26	11.0	M 10 x 40	⅝ x 1½	0.42		
420	1"	SAEFGA08-62	48.41	38.86	57.15	81	27.76	69.9	25	9.02	12.5	M 12 x 45	-	0.64		
420	1½"	SAEFGA10-62	54.76	44.45	66.68	95	31.75	77.2	30	9.78	14.5	M 14 x 50	½ x 1½	0.96		
420	1½"	SAEFGA12-62	64.29	51.56	79.38	113	36.50	95.0	33	12.07	17.0	M 16 x 60	⅝ x 2	1.62		
420	2"	SAEFGA16-62	80.16	67.56	96.82	133	44.45	113.8	38	12.07	21.0	M 20 x 70	⅝ x 2½	2.52		
420	2½"	SAEFGA20-62	108.90	90.00	123.80	180	58.80	190.2	45	20.50	26.0	M 24 x 75	-	4.92		
420	3"	SAEFGA24-62	132.50	115.00	152.40	215	71.80	198.2	55	25.50	31.0	M 30 x 90	-	10.32		



# SAE J 518 C 61/62 Flanges

SAE-flange clamp with tapped holes- flat

## SAEFGB

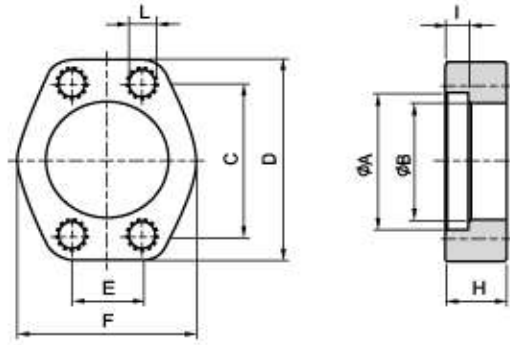

Maximum recommended working pressure kg/cm <sup>2</sup>	Nominal flange size, in	Type	Dimensions								Screws		Weight kg
			A	B	C	D	E	F	H	I	M		
											metr.	unc	
<b>Standard Pressure</b>													
350	½"	SAEFGB04-61	30.96	24.26	38.10	54	17.48	45.6	20	6.22	M 8 x 35	⅝" x 1½"	0.18
350	¾"	SAEFGB06-61	38.89	32.13	47.63	65	22.23	51.8	20	6.22	M 10 x 35	⅝" x 1½"	0.20
350	1"	SAEFGB08-61	45.24	38.48	52.37	70	26.19	58.4	22	7.49	M 10 x 35	⅝" x 1½"	0.26
420	1"	SAEFGB308-62	45.24	38.48	52.37	71	26.19	60.0	25	7.49	M 10 x 45	-	0.52
280	1½"	SAEFGB10-61	51.59	43.69	58.72	79	30.18	72.6	22	7.49	M 12 x 45	⅝" x 1½"	0.36
420	1½"	SAEFGB310-62	51.59	43.69	58.72	80	30.18	73.0	30	7.49	M 12 x 50	-	0.77
280	1½"	SAEFGB12-61	61.09	50.80	69.85	94	35.71	82.2	25	7.49	M 12 x 45	½" x 1½"	0.54
420	1½"	SAEFGB312-62	61.09	50.80	69.85	95	35.71	83.0	33	7.49	M 12 x 60	-	1.15
280	2"	SAEFGB16-61	72.24	62.74	77.77	102	42.88	96.4	30	9.02	M 12 x 50	½" x 1½"	0.60
420	2"	SAEFGB316-62	72.24	62.74	77.77	103	42.88	97.0	38	9.02	M 12 x 70	-	1.66
210	2½"	SAEFGB20-61	84.94	74.93	88.90	114	50.80	108.2	36	9.02	M 12 x 60	½" x 1½"	0.89
420	2½"	SAEFGB320-62	84.94	74.93	88.90	114	50.80	108.2	45	9.02	M 14 x 75	-	2.10
210	3"	SAEFGB24-61	102.39	90.93	106.38	135	61.93	130.6	41	9.02	M 16 x 70	⅝" x 2"	1.56
160	3½"	SAEFGB28-61	115.10	102.36	120.65	152	69.85	139.0	28	10.72	M 16 x 50	⅝" x 2"	1.80
160	4"	SAEFGB32-61	127.79	115.06	130.18	162	77.77	152.0	35	10.72	M 16 x 60	⅝" x 2"	1.98
35	5"	SAEFGB40-61	153.19	140.46	152.40	184	92.08	180.0	41	10.72	M 16 x 70	⅝" x 2"	3.00
<b>High Pressure</b>													
420	½"	SAEFGB04-62	32.54	24.26	40.49	56	18.24	47.2	22	7.24	M 8 x 35	⅝" x 1½"	0.19
420	¾"	SAEFGB06-62	42.06	32.51	50.80	71	23.80	60.0	23	8.26	M 10 x 40	⅝" x 1½"	0.42
420	1"	SAEFGB08-62	48.41	38.86	57.15	81	27.76	69.9	25	9.02	M 12 x 45	-	0.64
420	1½"	SAEFGB10-62	54.76	44.45	66.68	95	31.75	77.2	30	9.78	M 14 x 50	½" x 1½"	0.96
420	1½"	SAEFGB12-62	64.29	51.56	79.38	113	36.50	95.0	33	12.07	M 16 x 60	⅝" x 2"	1.62
420	2"	SAEFGB16-62	80.16	67.56	96.82	133	44.45	113.8	38	12.07	M 20 x 70	⅝" x 2½"	2.52
420	2½"	SAEFGB20-62	108.90	90.00	123.80	180	58.80	190.2	45	20.50	M 24 x 75	-	4.92
420	3"	SAEFGB24-62	132.50	115.00	152.40	215	71.60	198.16	55	25.50	M 30 x 90	-	10.32



# SAE J 518 C 61/62 Flanges

SAE - Pipe threaded flange

**SAAFS**

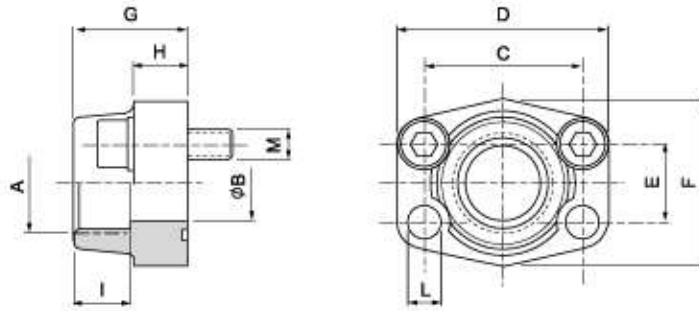

Maximum recommended working pressure kg/cm <sup>2</sup>	Nominal flange size, in	Type	Dimensions										Screws		Weight kg		
			A	B	C	D	E	F	G	H	I	L	M				
														metr.		unc	
		<b>Standard Pressure</b>															
350	½"	SAAFS 308-08R	R ½"	13	38.10	54	17.48	46	36	16	19	9.0	M 8 x 30	⅝ x 1 ¼	0.25		
350	¾"	SAAFS 312-12R	R ¾"	19	47.63	65	22.23	50	36	18	19	11.0	M 10 x 35	⅝ x 1 ½	0.39		
350	1"	SAAFS 316-16R	R 1"	25	52.37	70	26.19	55	38	18	22	11.0	M 10 x 35	⅝ x 1 ½	0.46		
280	1 ¼"	SAAFS 320-20R	R 1 ¼"	32	58.72	79	30.18	68	41	21	22	11.5	M 10 x 40	⅝ x 1 ½	0.66		
210	1 ½"	SAAFS 324-24R	R 1 ½"	38	69.85	93	35.71	78	45	25	24	13.5	M 12 x 40	⅝ x 1 ¾	1.05		
210	2"	SAAFS 332-32R	R 2"	51	77.77	102	42.88	90	45	25	30	13.5	M 12 x 45	⅝ x 1 ¾	1.19		
175	2 ½"	SAAFS 340-40R	R 2 ½"	63	88.90	114	50.80	105	50	25	30	13.5	M 12 x 45	⅝ x 1 ¾	1.40		
140	3"	SAAFS 348-48R	R 3"	73	106.38	134	61.93	124	50	27	34	17.0	M 16 x 50	⅝ x 2	2.15		
35	3 ½"	SAAFS 356-56R	R 3 ½"	89	120.65	152	69.85	136	48	27	34	17.0	M 16 x 51	⅝ x 2	2.40		
35	4"	SAAFS 364-64R	R 4"	99	130.18	182	77.77	146	48	27	34	17.0	M 16 x 52	⅝ x 2	2.85		
		<b>High Pressure</b>															
420	½"	SAAFS 608-08R	R ½"	13	40.49	54	18.24	46	36	16	19	9.0	M 8 x 30	⅝ x 1 ¼	0.26		
420	¾"	SAAFS 612-12R	R ¾"	19	50.80	71	23.80	55	35	21	22	11.0	M 10 x 35	⅝ x 1 ½	0.50		
420	1"	SAAFS 616-16R	R 1"	25	57.15	81	27.76	65	42	25	24	12.5	M 12 x 45	⅝ x 1 ½	0.76		
420	1 ¼"	SAAFS 620-20R	R 1 ¼"	32	66.68	95	31.75	78	45	27	25	14.5	M 14 x 45	⅝ x 1 ¾	1.20		
420	1 ½"	SAAFS 624-24R	R 1 ½"	38	79.38	112	36.50	94	50	30	28	17.0	M 16 x 50	⅝ x 2	1.65		
420	2"	SAAFS 632-32R	R 2"	51	96.82	134	44.45	114	65	37	30	21.0	M 20 x 65	⅝ x 2 ½	2.45		

# SAE J 518 C 61/62 Flanges

SAE pipe threaded flange - companion

**SAGFS**

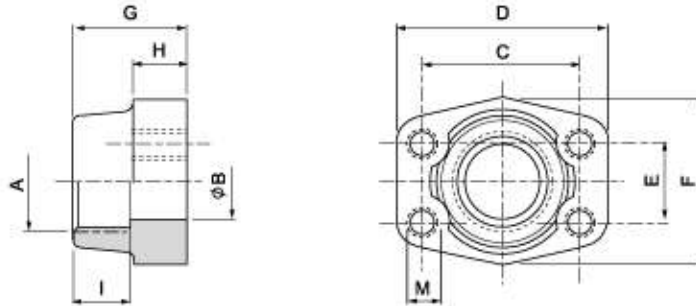

Maximum recommended working pressure kg/cm <sup>2</sup>	Nominal flange size, in	Type	Dimensions									Screws		Weight kg
			A	B	C	D	E	F	G	H	I	M		
												metr.	unc	
<b>Standard Pressure</b>														
350	½"	SAGFS 308-08R	R ½"	13	38.10	54	17.48	46	38	16	19	M 8	⅝	0.25
350	¾"	SAGFS 312-12R	R ¾"	19	47.63	65	22.23	50	36	18	19	M 10	⅝	0.39
350	1"	SAGFS 316-16R	R 1"	25	52.37	70	26.19	55	38	18	22	M 10	⅝	0.46
280	1¼"	SAGFS 320-20R	R 1¼"	32	58.72	79	30.18	68	41	21	22	M 10	⅝	0.66
210	1½"	SAGFS 324-24R	R 1½"	38	69.85	93	35.71	78	45	25	24	M 12	½	1.05
210	2"	SAGFS 332-32R	R 2"	51	77.77	102	42.88	90	45	25	30	M 12	½	1.19
175	2½"	SAGFS 340-40R	R 2½"	63	88.90	114	50.80	105	50	25	30	M 12	½	1.40
140	3"	SAGFS 348-48R	R 3"	73	106.38	134	61.93	124	50	27	34	M 16	⅝	2.15
35	3½"	SAGFS 356-56R	R 3½"	89	120.65	152	69.85	136	48	27	34	M 16	⅝	2.40
35	4"	SAGFS 364-64R	R 4"	99	130.18	162	77.77	146	48	27	34	M 16	⅝	2.85
<b>High Pressure</b>														
420	½"	SAGFS 608-08R	R ½"	13	40.49	54	18.24	46	36	16	19	M 8	⅝	0.26
420	¾"	SAGFS 612-12R	R ¾"	19	50.80	71	23.80	55	35	21	22	M 10	⅝	0.50
420	1"	SAGFS 616-16R	R 1"	25	57.15	81	27.76	65	42	25	24	M 12	⅝	0.76
420	1¼"	SAGFS 620-20R	R 1¼"	32	66.68	95	31.75	78	45	27	25	M 14	½	1.20
420	1½"	SAGFS 624-24R	R 1½"	38	79.38	112	36.50	94	50	30	28	M 16	⅝	1.65
420	2"	SAGFS 632-32R	R 2"	51	96.82	134	44.45	114	65	37	30	M 20	⅝	2.45

# SAE J 518 C 61/62 Flanges

SAE - NPT threaded flange

## SAAFS - N

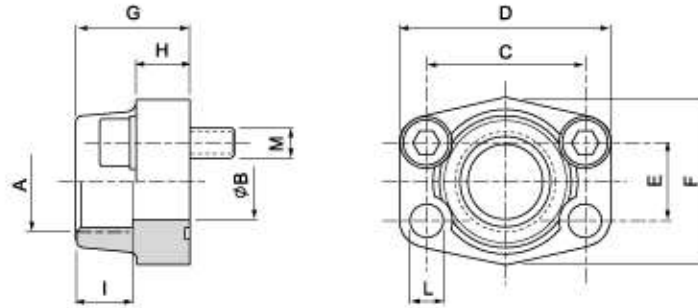

Maximum recommended working pressure kg/cm <sup>2</sup>	Nominal flange size, in	Type	Dimensions										Screws		Weight kg	
			A	B	C	D	E	F	G	H	I	L	M			
													metr.	unc		
		<b>Standard Pressure</b>														
350	½"	SAAFS 308-08N	½" NPT	13	38.10	54	17.48	46	36	16	19	9.0	M 8 x 30	⅝ x 1½	0.25	
350	¾"	SAAFS 312-12N	¾" NPT	19	47.63	65	22.23	50	36	18	19	11.0	M 10 x 35	⅝ x 1½	0.39	
350	1"	SAAFS 316-16N	1" NPT	25	52.37	70	26.19	55	38	18	22	11.0	M 10 x 35	⅝ x 1½	0.46	
280	1¼"	SAAFS 320-20N	1¼" NPT	32	58.72	79	30.18	68	41	21	22	11.5	M 10 x 40	⅝ x 1½	0.66	
210	1½"	SAAFS 324-24N	1½" NPT	38	69.85	93	35.71	78	45	25	24	13.5	M 12 x 45	⅝ x 1¾	1.05	
210	2"	SAAFS 332-32N	2" NPT	51	77.77	102	42.88	90	45	25	30	13.5	M 12 x 45	⅝ x 1¾	1.19	
175	2½"	SAAFS 340-40N	2½" NPT	63	88.90	114	50.80	105	50	25	30	13.5	M 12 x 45	⅝ x 1¾	1.40	
140	3"	SAAFS 348-48N	3" NPT	73	106.38	134	61.93	124	50	27	34	17.0	M 16 x 50	⅝ x 2	2.15	
35	3½"	SAAFS 356-56N	2½" NPT	89	120.65	152	69.85	136	48	27	34	17.0	M 16 x 50	⅝ x 2	2.40	
35	4"	SAAFS 364-64N	4" NPT	99	130.18	162	77.77	146	48	27	34	17.0	M 16 x 50	⅝ x 2	2.85	
		<b>High Pressure</b>														
420	½"	SAAFS 608-08N	½" NPT	13	40.49	54	18.24	46	36	16	19	9.0	M 8 x 30	⅝ x 1½	0.26	
420	¾"	SAAFS 612-12N	¾" NPT	19	50.80	71	23.80	55	35	21	22	11.0	M 10 x 35	⅝ x 1½	0.50	
420	1"	SAAFS 616-16N	1" NPT	25	57.15	81	27.76	65	42	25	24	12.5	M 12 x 45	⅝ x 1¾	0.76	
420	1¼"	SAAFS 620-20N	1¼" NPT	32	66.68	95	31.75	78	45	27	25	15.0	M 14 x 45	⅝ x 1¾	1.20	
420	1½"	SAAFS 624-24N	1½" NPT	38	79.38	112	36.50	94	50	30	28	17.0	M 16 x 50	⅝ x 2	1.65	
420	2"	SAAFS 632-32N	2" NPT	51	96.82	134	44.45	114	65	37	30	21.0	M 20 x 65	⅝ x 2½	2.45	



# SAE J 518 C 61/62 Flanges

SAE - NPT threaded flange - companion

**SAGFS - N**

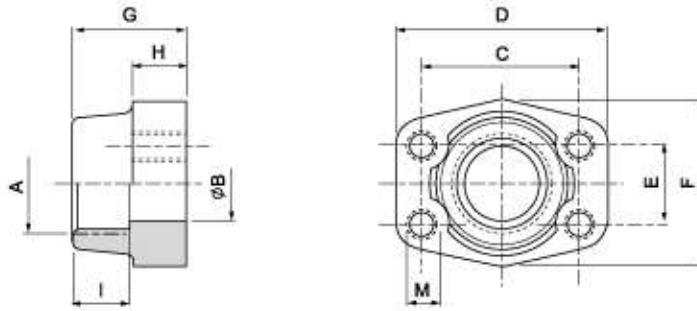

Maximum recommended working pressure kg/cm <sup>2</sup>	Nominal flange size, in	Type	Dimensions									Screws		Weight kg
			A	B	C	D	E	F	G	H	I	M		
												metr.	unc	
		<b>Standard Pressure</b>												
350	½"	SAGFS 308-08N	½" NPT	13	38.10	54	17.48	46	36	16	19	M 8	⅜"	0.25
350	¾"	SAGFS 312-12N	¾" NPT	19	47.63	65	22.23	50	36	18	19	M 10	⅜"	0.39
350	1"	SAGFS 316-16N	1" NPT	25	52.37	70	26.19	55	38	18	22	M 10	⅜"	0.46
280	1¼"	SAGFS 320-20N	1¼" NPT	32	58.72	79	30.18	68	41	21	22	M 10	⅜"	0.66
210	1½"	SAGFS 324-24N	1½" NPT	38	69.85	93	35.71	78	45	25	24	M 12	½"	1.05
210	2"	SAGFS 332-32N	2" NPT	51	77.77	102	42.88	90	45	25	30	M 12	½"	1.19
175	2½"	SAGFS 340-40N	2½" NPT	63	88.90	114	50.80	105	50	25	30	M 12	½"	1.40
140	3"	SAGFS 348-48N	3" NPT	73	106.38	134	61.93	124	50	27	34	M 16	⅝"	2.15
35	3½"	SAGFS 356-56N	2½" NPT	89	120.65	152	69.85	136	48	27	34	M 16	⅝"	2.40
35	4"	SAGFS 364-64N	4" NPT	99	130.18	162	77.77	146	48	27	34	M 16	⅝"	2.85
		<b>High Pressure</b>												
420	½"	GFS 608-08N	½" NPT	13	40.49	54	18.24	46	36	16	19	M 8	⅜"	0.26
420	¾"	AFS 612-12N	¾" NPT	19	50.80	71	23.80	55	35	21	22	M 10	⅜"	0.50
420	1"	AFS 616-16N	1" NPT	25	57.15	81	27.76	65	42	25	24	M 12	⅜"	0.76
420	1¼"	GFS 620-20N	1¼" NPT	32	66.68	95	31.75	78	45	27	25	M 14	½"	1.20
420	1½"	GFS 624-24N	1½" NPT	38	79.38	112	36.50	94	50	30	28	M 16	⅝"	1.65
420	2"	GFS 632-32N	2" NPT	51	96.82	134	44.45	114	65	37	30	M 20	⅝"	2.45

# SAE J 518 C 61/62 Flanges

SAE - UN - threaded flange

## SAAFS - U

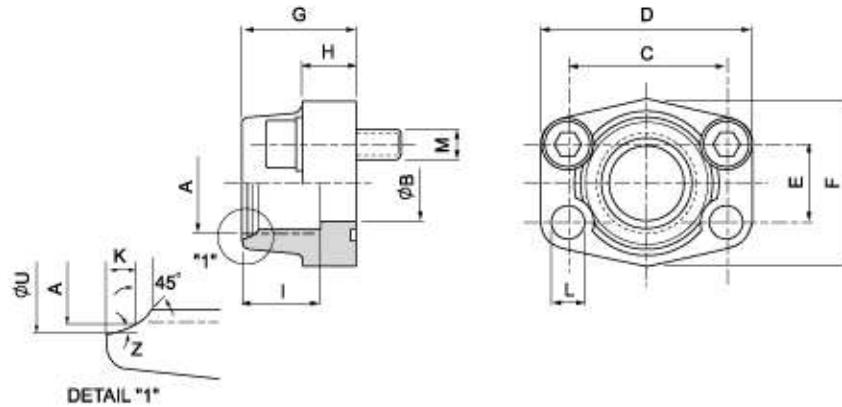

Maximum recommended working pressure kg/cm <sup>2</sup>	Nominal flange size, in	Type	Dimensions													Screws		Weight kg	
			A	B	C	D	E	F	G	H	I	L	U	E	Z	M			
																	metr.		unc
<b>Standard Pressure</b>																			
350	½"	SAAFS 308-08U	¾"-16UNF	13	38.10	54	17.48	46	36	16	17	9.0	20.6	2.5	15°	M 8 x 30	⅝" x 1¼"	0.25	
350	¾"	SAAFS 312-12U	1 ⅛"-12UN	19	47.63	65	22.23	50	36	18	23	11.0	29.2	3.3	15°	M 10 x 35	⅝" x 1½"	0.39	
350	1"	SAAFS 316-16U	1 ⅝"-12UN	25	52.37	70	26.19	55	38	18	23	11.0	35.5	3.3	15°	M 10 x 35	⅝" x 1½"	0.46	
280	1 ¼"	SAAFS 320-20U	1 ¾"-12UN	32	58.72	79	30.18	68	42	21	23	11.5	43.5	3.3	15°	M 10 x 40	⅝" x 1½"	0.66	
210	1 ½"	SAAFS 324-24U	1 ¾"-12UN	38	69.85	93	35.71	78	45	25	23	13.5	49.8	3.3	15°	M 12 x 45	⅝" x 1¾"	1.05	
<b>High Pressure</b>																			
420	½"	SAAFS 608-08U	¾"-16UNF	13	40.49	54	18.24	46	36	16	17	9.0	20.6	2.5	15°	M 8 x 30	⅝" x 1¼"	0.26	
420	¾"	SAAFS 612-12U	1 ⅛"-12UN	19	50.80	71	23.80	55	35	21	23	11.0	29.3	3.3	15°	M 10 x 35	⅝" x 1½"	0.50	
420	1"	SAAFS 616-16U	1 ⅝"-12UN	25	57.15	81	27.76	65	42	25	23	12.5	35.5	3.3	15°	M 12 x 45	⅝" x 1¾"	0.76	
420	1 ¼"	SAAFS 620-20U	1 ¾"-12UN	32	66.68	95	31.75	78	45	27	23	14.5	43.5	3.3	15°	M 14 x 45	⅝" x 1¾"	1.20	
420	1 ½"	SAAFS 624-24U	1 ¾"-12UN	38	79.38	112	36.50	94	50	30	23	17.0	49.8	3.3	15°	M 16 x 50	⅝" x 2"	1.65	

# SAE J 518 C 61/62 Flanges

SAE - metric threaded flange DIN 3901/3902

## SAAFG

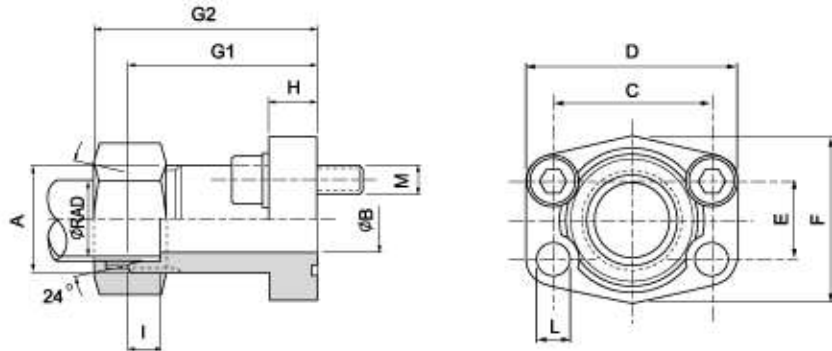

Maximum recommended working pressure kg/cm <sup>2</sup>	Nominal flange size, in	Type	Dimensions											Screws		Weight kg	
			A	B	C	D	E	F	G <sub>1</sub>	G <sub>2</sub>	H	I	L	M			
			metr.		unc												
<b>Standard Pressure</b>																	
315	½"	SAAFG 308-15L	M 22 x 1.5	12	38.10	54	17.48	46	52	60	13	7.0	9.0	M 8 x 30	⅝" x 1½"	0.25	
160	¾"	SAAFG 312-22L	M 30 x 2	19	47.63	65	22.23	50	60	69	14	7.5	11.0	M 10 x 30	⅝" x 1½"	0.35	
350	¾"	SAAFG 312-20S	M 30 x 2	16	47.63	65	22.23	50	60	73	14	10.5	11.0	M 10 x 30	⅝" x 1½"	0.36	
160	1"	SAAFG 316-22L	M 30 x 2	19	52.37	70	26.19	55	63	72	16	7.5	11.0	M 10 x 30	⅝" x 1½"	0.44	
160	1"	SAAFG 316-28L	M 36 x 2	24	52.37	70	26.19	55	63	72	16	7.5	11.0	M 10 x 30	⅝" x 1½"	0.50	
350	1"	SAAFG 316-20S	M 30 x 2	16	52.37	70	26.19	55	63	76	16	10.5	11.0	M 10 x 30	⅝" x 1½"	0.46	
350	1"	SAAFG 316-25S	M 36 x 2	20	52.37	70	26.19	55	63	75	14	12.0	11.0	M 10 x 30	⅝" x 1½"	0.52	
160	1½"	SAAFG 320-28L	M 36 x 2	24	58.72	79	30.18	68	65	74	14	7.5	11.5	M 10 x 35	⅝" x 1½"	0.68	
160	1½"	SAAFG 320-35L	M 45 x 2	29	58.72	79	30.18	68	65	76	14	10.5	11.5	M 10 x 35	⅝" x 1½"	0.72	
280	1½"	SAAFG 320-30S	M 42 x 2	25	58.72	81	30.18	68	65	78	14	13.0	11.5	M 10 x 35	⅝" x 1½"	0.70	
160	1½"	SAAFG 324-40L	M 52 x 2	36	69.85	94	35.71	78	70	82	16	11.0	13.5	M 12 x 35	⅝" x 1½"	1.00	
210	1½"	SAAFG 327-38S	M 52 x 2	32	69.85	94	35.71	78	70	82	16	10.0	13.5	M 12 x 35	⅝" x 1½"	1.02	
<b>High Pressure</b>																	
420	½"	SAAFG 608-16S	M 24 x 1.5	12	40.49	56	18.24	48	60	70	16	8.5	9.0	M 8 x 30	⅝" x 1½"	0.30	
420	¾"	SAAFG 612-25S	M 36 x 2	19	50.80	71	23.80	60	73	85	19	12.0	11.0	M 10 x 35	⅝" x 1½"	0.68	
420	1"	SAAFG 616-30S	M 42 x 2	25	57.15	81	27.76	70	82	95	24	13.5	12.5	M 12 x 45	⅝" x 1½"	1.00	
420	1½"	SAAFG 620-38S	M 52 x 2	29	66.68	95	31.75	78	92	107	27	16.0	14.5	M 14 x 50	⅝" x 1½"	1.60	
420	1½"	SAAFG 620-30S	M 42 x 2	25	66.68	95	31.75	78	92	106	27	13.5	14.5	M 14 x 50	⅝" x 1½"	1.54	
420	1½"	SAAFG 624-38S	M 52 x 2	32	79.38	113	36.50	95	96	111	30	16.0	17.0	M 16 x 50	⅝" x 2"	2.20	



# SAE J 518 C 61/62 Flanges

SAE - DIN 2353 connection flange DIN 3901/3902

## SASFCE

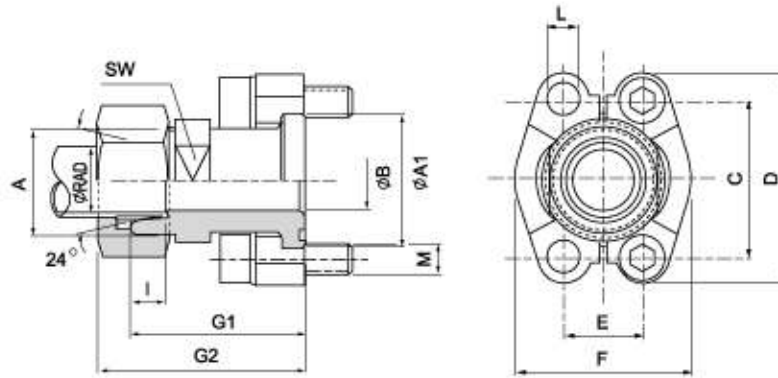

Maximum recommended working pressure kg/cm <sup>2</sup>	Nominal flange size, in	Type	Dimensions											Screws		Weight kg		
			A	B	C	D	E	F	G <sub>1</sub>	G <sub>2</sub>	I	L	SW	M				
			metr.	unc	metr.	unc	metr.	unc	metr.	unc	metr.	unc	metr.	unc	metr.		unc	
		<b>Standard Pressure</b>																
315	1/2"	SASFCE 308-15L	M 22 x 1.5	30.2	38.10	54	17.48	45.6	48.2	56	7.0	9.0	24	M 8 x 25	5/16 x 1 1/4	0.29		
350	1/2"	SASFCE 308-16S	M 24 x 1.5	30.2	38.10	54	17.48	45.6	50.2	60	8.5	9.0	24	M 8 x 25	5/16 x 1 1/4	0.32		
315	3/4"	SASFCE 312-18L	M 26 x 1.5	38.1	47.63	65	22.23	51.8	53.2	62	7.5	11.0	30	M 10 x 30	3/8 x 1 1/2	0.55		
160	3/4"	SASFCE 312-22L	M 30 x 2	38.1	47.63	65	22.23	51.8	53.2	62	7.5	11.0	30	M 10 x 30	3/8 x 1 1/2	0.56		
160	3/4"	SASFCE 312-28L	M 36 x 2	38.1	47.63	65	22.23	51.8	53.2	62	7.5	11.0	30	M 10 x 30	3/8 x 1 1/2	0.75		
350	3/4"	SASFCE 312-20S	M 30 x 2	38.1	47.63	65	22.23	51.8	57.2	68	11.0	11.0	30	M 10 x 30	3/8 x 1 1/2	0.63		
350	1"	SASFCE 316-25S	M 36 x 2	38.1	47.63	65	22.23	51.8	57.2	69	12.0	11.0	30	M 10 x 30	3/8 x 1 1/2	0.76		
160	1"	SASFCE 316-28L	M 36 x 2	44.4	52.37	70	26.19	58.4	54.2	65	7.5	11.0	36	M 10 x 30	3/8 x 1 1/2	0.69		
350	1"	SASFCE 316-25S	M 36 x 2	44.4	52.37	70	26.19	58.4	58.2	70	12.0	11.0	36	M 10 x 30	3/8 x 1 1/2	0.78		
350	1"	SASFCE 316-30S	M 42 x 2	44.4	52.37	70	26.19	58.4	63.2	76	14.0	11.0	36	M 10 x 30	3/8 x 1 1/2	0.91		
160	1 1/4"	SASFCE 320-28L	M 36 x 2	50.8	58.72	79	30.18	72.6	58.6	67	7.5	11.5	36	M 10 x 40	3/8 x 1 1/2	1.05		
160	1 1/4"	SASFCE 320-35L	M 45 x 2	50.8	58.72	79	30.18	72.6	58.2	69	11.0	11.5	41	M 10 x 40	3/8 x 1 1/2	1.10		
280	1 1/4"	SASFCE 320-25S	M 36 x 2	50.8	58.72	79	30.18	72.6	60.2	72	12.0	11.5	41	M 10 x 40	3/8 x 1 1/2	1.17		
280	1 1/4"	SASFCE 320-30S	M 42 x 2	50.8	58.72	79	30.18	72.6	62.2	75	14.0	11.5	41	M 10 x 40	3/8 x 1 1/2	1.19		
280	1 1/4"	SASFCE 320-38S	M 52 x 2	50.8	58.72	79	30.18	72.6	66.6	81	16.0	11.5	46	M 10 x 40	3/8 x 1 1/2	1.39		
160	1 1/2"	SASFCE 324-42L	M 52 x 2	60.3	69.85	94	35.71	82.2	64.2	76	11.0	13.5	46	M 12 x 35	1/2 x 1 1/2	1.34		
210	1 1/2"	SASFCE 324-38S	M 52 x 2	60.3	69.85	94	35.71	82.2	70.2	85	16.0	13.5	46	M 12 x 35	1/2 x 1 1/2	1.50		

# SAE J 518 C 61/62 Flanges

SAE - DIN 2353 connection flange DIN 3901/3902

## SASFCE

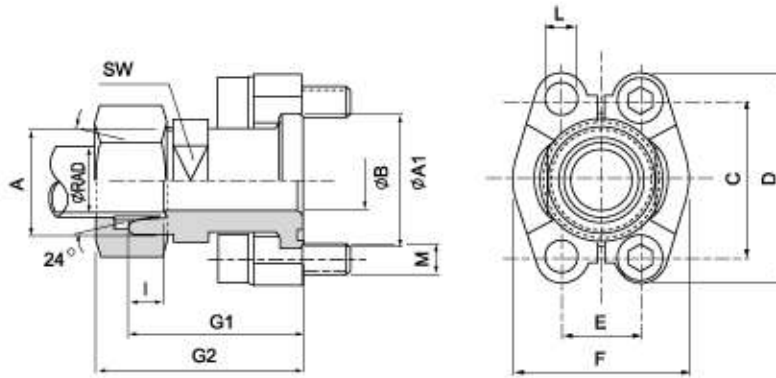

Maximum recommended working pressure kg/cm <sup>2</sup>	Nominal flange size, in	Type	Dimensions											Screws		Weight kg		
			A	B	C	D	E	F	G <sub>1</sub>	G <sub>2</sub>	I	L	SW	M				
														metr.	unc			
		<b>Standard Pressure</b>																
315	1/2"	SASFCE 308-15L	M 22 x 1.5	30.2	38.10	54	17.48	45.6	48.2	56	7.0	9.0	24	M 8 x 25	5/16 x 1 1/4	0.29		
350	1/2"	SASFCE 308-16S	M 24 x 1.5	30.2	38.10	54	17.48	45.6	50.2	60	8.5	9.0	24	M 8 x 25	5/16 x 1 1/4	0.32		
315	3/4"	SASFCE 312-18L	M 26 x 1.5	38.1	47.63	65	22.23	51.8	53.2	62	7.5	11.0	30	M 10 x 30	3/8 x 1 1/2	0.55		
160	3/4"	SASFCE 312-22L	M 30 x 2	38.1	47.63	65	22.23	51.8	53.2	62	7.5	11.0	30	M 10 x 30	3/8 x 1 1/2	0.56		
160	3/4"	SASFCE 312-28L	M 36 x 2	38.1	47.63	65	22.23	51.8	53.2	62	7.5	11.0	30	M 10 x 30	3/8 x 1 1/2	0.75		
350	3/4"	SASFCE 312-20S	M 30 x 2	38.1	47.63	65	22.23	51.8	57.2	68	11.0	11.0	30	M 10 x 30	3/8 x 1 1/2	0.63		
350	1"	SASFCE 316-25S	M 36 x 2	38.1	47.63	65	22.23	51.8	57.2	69	12.0	11.0	30	M 10 x 30	3/8 x 1 1/2	0.76		
160	1"	SASFCE 316-28L	M 36 x 2	44.4	52.37	70	26.19	58.4	54.2	65	7.5	11.0	36	M 10 x 30	3/8 x 1 1/2	0.69		
350	1"	SASFCE 316-25S	M 36 x 2	44.4	52.37	70	26.19	58.4	58.2	70	12.0	11.0	36	M 10 x 30	3/8 x 1 1/2	0.78		
350	1"	SASFCE 316-30S	M 42 x 2	44.4	52.37	70	26.19	58.4	63.2	76	14.0	11.0	36	M 10 x 30	3/8 x 1 1/2	0.91		
160	1 1/4"	SASFCE 320-28L	M 36 x 2	50.8	58.72	79	30.18	72.6	58.6	67	7.5	11.5	36	M 10 x 40	3/8 x 1 1/2	1.05		
160	1 1/4"	SASFCE 320-35L	M 45 x 2	50.8	58.72	79	30.18	72.6	58.2	69	11.0	11.5	41	M 10 x 40	3/8 x 1 1/2	1.10		
280	1 1/4"	SASFCE 320-25S	M 36 x 2	50.8	58.72	79	30.18	72.6	60.2	72	12.0	11.5	41	M 10 x 40	3/8 x 1 1/2	1.17		
280	1 1/4"	SASFCE 320-30S	M 42 x 2	50.8	58.72	79	30.18	72.6	62.2	75	14.0	11.5	41	M 10 x 40	3/8 x 1 1/2	1.19		
280	1 1/4"	SASFCE 320-38S	M 52 x 2	50.8	58.72	79	30.18	72.6	66.6	81	16.0	11.5	46	M 10 x 40	3/8 x 1 1/2	1.39		
160	1 1/2"	SASFCE 324-42L	M 52 x 2	60.3	69.85	94	35.71	82.2	64.2	76	11.0	13.5	46	M 12 x 35	1/2 x 1 1/2	1.34		
210	1 1/2"	SASFCE 324-38S	M 52 x 2	60.3	69.85	94	35.71	82.2	70.2	85	16.0	13.5	46	M 12 x 35	1/2 x 1 1/2	1.50		

# SAE J 518 C 61/62 Flanges

SAE - DIN 2353 connection flange DIN 3901/3902

**SASFCE**

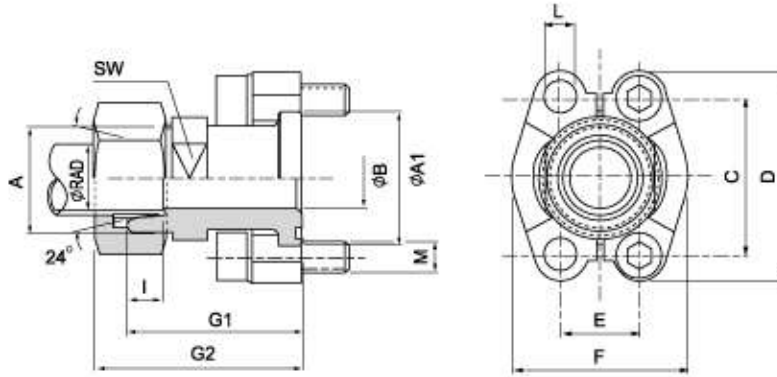

Maximum recommended working pressure kg/cm <sup>2</sup>	Nominal flange size, in	Type	Dimensions												Screws			
			A	A <sub>1</sub>	B	C	D	E	F	G <sub>1</sub>	G <sub>2</sub>	I	L	SW	M			
																metr.	unc.	
		<b>High Pressure</b>																
400	½"	SASFCE 608-16S	M 24 x 1.5	32	12	40.49	56	18.24	47	53	63	8.5	9.0	24	M 8 x 25	⅝ x 1½		
400	¾"	SASFCE 612-16S	M 24 x 1.5	41	12	50.80	71	23.80	60	59	69	8.5	11.1	30	M 10 x 35	⅝ x 1½		
400	¾"	SASFCE 612-20S	M 30 x 2	41	16	50.80	71	23.80	60	61	72	11.0	11.0	30	M 10 x 35	⅝ x 1½		
400	¾"	SASFCE 612-25S	M 36 x 2	41	17	50.80	71	23.80	60	63	75	12.0	11.0	30	M 10 x 35	⅝ x 1½		
400	¾"	SASFCE 612-30S	M 42 x 2	41	18	50.80	71	23.80	60	64	77	14.0	11.0	36	M 10 x 35	⅝ x 1½		
400	1"	SASFCE 616-25S	M 36 x 2	48	20	57.15	81	27.76	70	72	84	12.0	12.5	41	M 12 x 45	⅝ x 1½		
400	1"	SASFCE 616-30S	M 42 x 2	48	24	57.15	81	27.75	70	74	87	14.0	12.5	41	M 12 x 45	⅝ x 1½		
400	1½"	SASFCE 620-30S	M 42 x 2	54	20/30	66.68	95	31.75	77	79	92	14.0	14.5	41	M 14 x 50	⅝ x 1½		
400	1½"	SASFCE 620-38S	M 52 x 2	54	30	66.68	95	31.75	77	83	98	16.0	14.5	46	M 14 x 50	⅝ x 1½		
400	1½"	SASFCE 624-38S	M 52 x 2	64	30	79.38	113	36.50	95	89	104	16.0	17.0	46	M 16 x 55	⅝ x 2		



# SAE J 518 C 61/62 Flanges

SAE - JIC 37° flared connection

## SAAFG - J

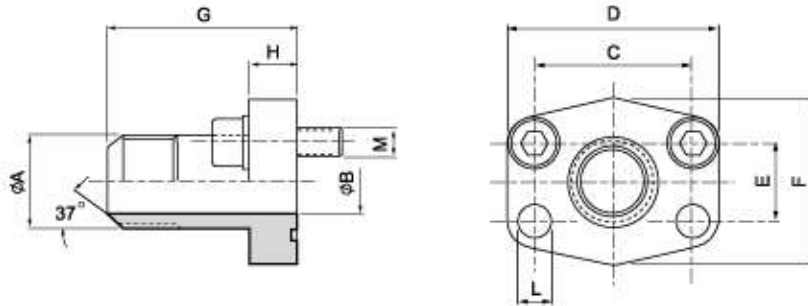

Maximum recommended working pressure kg/cm <sup>2</sup>	Nominal flange size, in	Type	Dimensions										Screws		Weight kg
			A	B	C	D	E	F	G	H	L	M			
												metr.	unc		
<b>Standard Pressure</b>															
350	½"	SAAFG 308-08J	⅜"-16 JIC	9.9	38.10	54	17.48	46	52	13	9.0	M 8 x 30	⅝" x 1¼"	0.25	
350	½"	SAAFG 308-10J	⅜"-14 JIC	12.3	38.10	54	17.48	46	52	13	9.0	M 8 x 30	⅝" x 1¼"	0.30	
350	¾"	SAAFG 312-12J	1 ⅛"-12 JIC	15.5	47.63	65	22.23	50	60	14	11.0	M 10 x 30	⅝" x 1¼"	0.35	
350	1"	SAAFG 316-16J	1 ⅝"-12 JIC	21.5	52.37	70	26.19	55	63	16	11.0	M 10 x 30	⅝" x 1¼"	0.50	
280	1 ¼"	SAAFG 320-20J	1 ⅝"-12 JIC	27.5	58.72	79	30.18	68	65	14	11.5	M 10 x 30	⅝" x 1½"	0.70	
280	1 ¼"	SAAFG 320-16J	1 ⅝"-12 JIC	21.5	58.72	79	30.18	68	65	14	11.5	M 10 x 30	⅝" x 1½"	0.70	
210	1 ½"	SAAFG 324-24J	1 ¾"-12 JIC	33.0	69.85	94	35.71	78	70	16	13.5	M 12 x 35	⅝" x 1½"	1.00	
<b>High Pressure</b>															
420	½"	SAAFG 608-08J	⅜"-16 JIC	9.9	40.49	56	18.24	48	60	16	9.0	M 8 x 30	⅝" x 1¼"	0.30	
420	½"	SAAFG 608-10J	⅜"-14 JIC	12.3	40.49	56	18.24	48	60	16	9.0	M 8 x 30	⅝" x 1¼"	0.40	
420	¾"	SAAFG 612-12J	1 ⅛"-12 JIC	15.5	50.80	71	23.80	60	73	19	11.0	M 10 x 35	⅝" x 1½"	0.70	
420	1"	SAAFG 616-16J	1 ⅝"-12 JIC	21.5	57.15	81	27.78	70	82	24	12.5	M 12 x 45	⅝" x 1½"	1.00	
420	1 ¼"	SAAFG 620-20J	1 ⅝"-12 JIC	27.5	66.68	95	31.75	78	92	27	14.5	M 14 x 45	⅝" x 1½"	1.50	
420	1 ¼"	SAAFG 620-16J	1 ⅝"-12 JIC	21.5	66.68	95	31.75	78	92	27	14.5	M 14 x 45	⅝" x 1½"	1.50	
420	1 ½"	SAAFG 624-24J	1 ¾"-12 JIC	33.0	79.38	113	36.50	95	96	30	17.0	M 16 x 50	⅝" x 2"	2.30	

# SAE J 518 C 61/62 Flanges

SAE - socket weld flange

**SAAFS - SW**

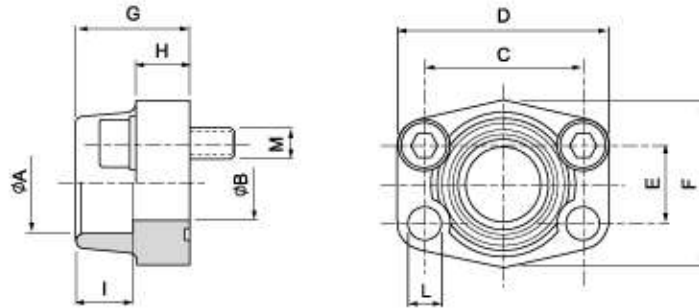

Maximum recommended working pressure kg/cm <sup>2</sup>	Nominal flange size, in	Type	Dimensions										Screws		Weight kg		
			A	B	C	D	E	F	G	H	I	L	M				
			metr.		unc												
<b>Standard Pressure</b>																	
350	½"	SAAFS 308-08 SW	21.6	13	38.10	54	17.48	46	36	16	19	9.0	M 8 x 30	⅜ x 1½	0.25		
350	¾"	SAAFS 312-12 SW	27.2	19	47.63	65	22.23	50	36	18	19	11.0	M 10 x 35	⅜ x 1½	0.39		
350	1"	SAAFS 316-16 SW	34.0	25	52.37	70	26.19	55	38	18	19	11.0	M 10 x 35	⅜ x 1½	0.46		
280	1½"	SAAFS 320-20 SW	42.8	32	58.72	79	30.18	68	41	21	22	11.5	M 10 x 40	⅜ x 1½	0.66		
210	1½"	SAAFS 324-24 SW	48.6	38	69.85	93	35.71	78	45	25	24	13.5	M 12 x 45	½ x 1¾	1.05		
210	2"	SAAFS 332-32 SW	61.0	51	77.77	102	42.88	90	45	25	26	13.5	M 12 x 45	½ x 1¾	1.19		
175	2½"	SAAFS 340-40 SW	73.5	63	88.90	114	50.80	105	50	25	30	13.5	M 12 x 45	½ x 1¾	1.40		
140	3"	SAAFS 348-48 SW	90.5	76	106.38	134	61.93	124	50	27	34	17.0	M 16 x 50	⅝ x 2	2.15		
35	3½"	SAAFS 356-56 SW	103.0	89	120.65	152	69.85	136	48	27	34	17.0	M 16 x 50	⅝ x 2	2.40		
35	4"	SAAFS 364-64 SW	115.0	102	130.18	162	77.77	146	48	27	34	17.0	M 16 x 50	⅝ x 2	2.85		
<b>High Pressure</b>																	
420	½"	SAAFS 608-08 SW	21.6	13	40.49	54	18.24	46	36	16	19	9.0	M 8 x 30	⅜ x 1½	0.26		
420	¾"	SAAFS 612-12 SW	27.2	19	50.80	71	23.80	55	35	21	22	11.0	M 10 x 35	⅜ x 1½	0.50		
420	1"	SAAFS 616-16 SW	34.0	25	57.15	81	27.76	65	42	25	22	12.5	M 12 x 45	⅜ x 1¾	0.76		
420	1½"	SAAFS 620-20 SW	42.8	32	66.68	95	31.75	78	45	27	25	14.5	M 14 x 45	½ x 1¾	1.20		
420	1½"	SAAFS 624-24 SW	48.6	38	79.38	112	36.50	94	50	30	8	17.0	M 16 x 50	⅝ x 2	1.65		
420	2"	SAAFS 632-32 SW	61.0	51	96.82	134	44.45	114	65	37	24	21.0	M 20 x 65	⅝ x 2½	2.45		
420	2½"	SAAFS 640-40 SW	73.5	63	123.80	180	58.70	152	80	45	30	26.0	M 24 x 75	-	8.30		

# SAE J 518 C 61/62 Flanges

SAE - socket weld flange companion

## SAGFS - SW

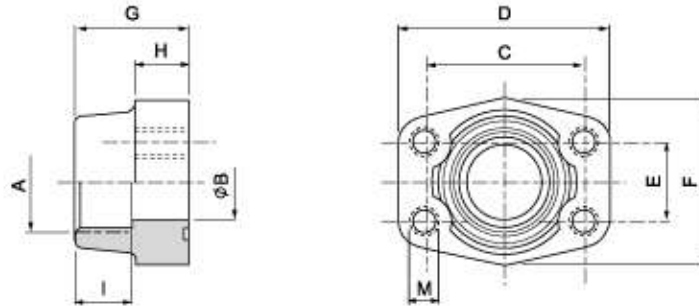

Maximum recommended working pressure kg/cm <sup>2</sup>	Nominal flange size, in	Type	Dimensions									Screws		Weight kg
			A	B	C	D	E	F	G	H	I	M		
												metr.	unc	
<b>Standard Pressure</b>														
350	½"	SAGFS 308-08 SW	21.6	13	38.10	54	17.48	46	36	16	19	M 8	⅜	0.25
350	¾"	SAGFS 312-12 SW	27.2	19	47.63	65	22.23	50	36	18	19	M 10	⅜	0.39
350	1"	SAGFS 316-16 SW	34.0	25	52.37	70	26.19	55	38	18	19	M 10	⅜	0.46
280	1¼"	SAGFS 320-20 SW	42.8	32	58.72	79	30.18	68	41	21	22	M 10	⅜	0.66
210	1½"	SAGFS 324-24 SW	48.6	38	69.85	93	35.71	78	45	25	24	M 12	½	1.05
210	2"	SAGFS 332-32 SW	61.0	51	77.77	102	42.88	90	45	25	26	M 12	½	1.19
175	2½"	SAGFS 340-40 SW	73.5	63	88.90	114	50.80	105	50	25	30	M 12	½	1.40
140	3"	SAGFS 348-48 SW	90.5	76	106.38	134	61.93	124	50	27	34	M 16	⅝	2.15
35	3½"	SAGFS 356-56 SW	103.0	89	120.65	152	69.85	136	48	27	34	M 16	⅝	2.40
35	4"	SAGFS 364-64 SW	115.0	102	130.18	162	77.77	146	48	27	34	M16	⅝	2.85
<b>High Pressure</b>														
420	½"	SAGFS 608-08 SW	21.6	13	40.49	54	18.24	46	36	16	19	M 8	⅜ x 1¼	0.26
420	¾"	SAGFS 612-12 SW	27.2	19	50.80	71	23.80	55	35	21	22	M 10	⅜ x 1½	0.50
420	1"	SAGFS 616-16 SW	34.0	25	57.15	81	27.76	65	42	25	22	M 12	⅜ x 1¾	0.76
420	1¼"	SAGFS 620-20 SW	42.8	32	66.68	95	31.75	78	45	27	25	M 14	½ x 1¾	1.20
420	1½"	SAGFS 624-24 SW	48.6	38	79.38	112	36.50	94	50	30	8	M 16	⅝ x 2	1.65
420	2"	SAGFS 632-32 SW	61.0	51	96.82	134	44.45	114	65	37	24	M 20	⅝ x 2½	2.45
420	2½"	SAGFS 640-40 SW	73.5	63	123.80	180	58.70	152	80	45	30	M 24	-	8.30



# SAE J 518 C 61/62 Flanges

SAE - socket weld flange

**SADFS - SW**

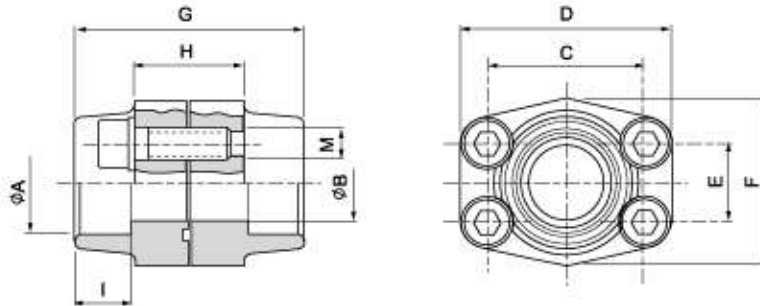

Maximum recommended working pressure kg/cm <sup>2</sup>	Nominal flange size, in	Type	Dimensions									Screws		Weight kg
			A	B	C	D	E	F	G	H	I	M		
												metr.	unc	
<b>Standard Pressure</b>														
350	½"	SADFS 308-08 SW	21.6	13	38.10	54	17.48	46	72	32	19	M 8 x 30	⅝ x 1½	0.50
350	¾"	SADFS 312-12 SW	27.2	19	47.63	65	22.23	50	72	36	19	M 10 x 35	⅝ x 1½	0.78
350	1"	SADFS 316-16 SW	34.0	25	52.37	70	26.19	55	76	36	19	M 10 x 35	⅝ x 1½	0.92
280	1½"	SADFS 320-20 SW	42.8	32	58.72	79	30.18	68	82	42	22	M 10 x 40	⅞ x 1½	1.32
210	1½"	SADFS 324-24 SW	48.6	38	69.85	93	35.71	78	90	50	24	M 12 x 45	½ x 1¾	2.10
210	2"	SADFS 332-32 SW	61.0	51	77.77	102	42.88	90	90	50	26	M 12 x 45	½ x 1¾	2.38
175	2½"	SADFS 340-40 SW	73.5	63	88.90	114	50.80	105	100	50	30	M 12 x 45	½ x 1¾	2.80
140	3"	SADFS 348-48 SW	90.5	76	106.38	134	61.93	124	100	54	34	M 16 x 50	⅝ x 2	4.30
35	3½"	SADFS 356-56 SW	103.0	89	120.65	152	69.85	136	96	54	34	M 16 x 50	⅝ x 2	4.80
35	4"	SADFS 364-64 SW	115.0	102	130.18	162	77.77	146	96	54	34	M 16 x 50	⅝ x 2	5.70
<b>High Pressure</b>														
420	½"	SADFS 608-08 SW	21.6	13	40.49	54	18.24	46	72	32	19	M 8 x 30	⅝ x 1½	0.52
420	¾"	SADFS 612-12 SW	27.2	19	50.80	71	23.80	55	70	42	22	M 10 x 35	⅝ x 1½	1.00
420	1"	SADFS 616-16 SW	34.0	25	57.15	81	27.76	65	84	50	22	M 12 x 45	⅞ x 1¾	1.52
420	1½"	SADFS 620-20 SW	42.8	32	66.68	95	31.75	78	90	54	25	M 14 x 45	½ x 1¾	2.40
420	1½"	SADFS 624-24 SW	48.6	38	79.38	112	36.50	94	100	60	8	M 16 x 50	⅝ x 2	3.30
420	2"	SADFS 632-32 SW	61.0	51	96.82	134	44.45	114	130	74	24	M 20 x 65	⅝ x 2½	4.90

# SAE J 518 C 61/62 Flanges

SAE - socket weld flange 500 psi

## SA AFC - SW

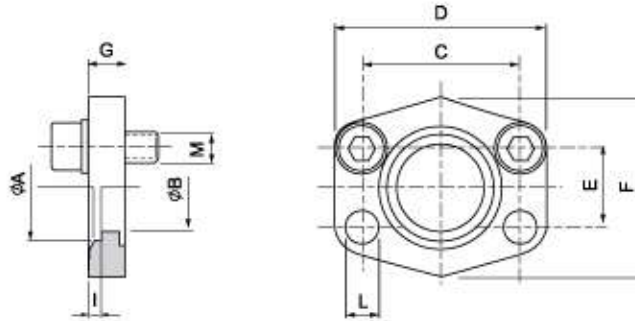

Maximum recommended working pressure kg/cm <sup>2</sup>	Nominal flange size, in	Type	Nominal pipe size	Dimensions								Screws		Weight kg	
				A	B	C	D	E	F	G	I	L	M		
															metr.
		<b>Standard Pressure</b>													
40	½"	SA AFC 08 SW	21.3 x 3.7	21.6	13	38.10	56	17.48	46	10	3	9.0	M 8 x 25	-	0.12
40	¾"	SA AFC 12 SW	26.7 x 3.9	27.2	19	47.63	65	22.23	50	12	4	11.0	M 10 x 30	-	0.20
40	1"	SA AFC 16 SW	33.4 x 4.5	34.0	25	52.37	70	26.19	55	12	4	11.0	M 10 x 30	-	0.25
40	1 ¼"	SA AFC 20 SW	42.2 x 4.9	42.8	32	58.72	79	30.18	68	12	4	11.5	M 10 x 30	-	0.31
40	1 ½"	SA AFC 24 SW	48.3 x 5.1	48.6	38	69.85	93	35.71	78	15	4	13.5	M 12 x 35	-	0.50
40	2"	SA AFC 32 SW	60.3 x 5.5	61.0	51	77.77	102	42.88	90	15	4	13.5	M 12 x 35	-	0.59
40	2 ½"	SA AFC 40 SW	73.0 x 7.0	73.5	63	88.90	114	50.80	105	15	4	13.5	M 12 x 35	-	0.72
40	3"	SA AFC 48 SW	88.9 x 7.6	90.5	76	106.38	134	61.93	124	20	5	17.0	M 16 x 40	-	1.25
40	3 ½"	SA AFC 56 SW	101.5 x 8.1	103.5	89	120.65	152	69.85	136	20	5	17.0	M 16 x 40	-	1.50
40	4"	SA AFC 64 SW	114.3 x 8.8	115.0	102	130.18	162	77.77	146	25	6	17.0	M 16 x 45	-	2.15
40	5"	SA AFC 80 SW	141.3 x 9.5	143.0	127	152.40	190	92.08	170	28	8	17.0	M 16 x 45	-	3.00

# SAE J 518 C 61/62 Flanges

SAE - socket weld flange 500 psi - companion

## SAGFC - SW

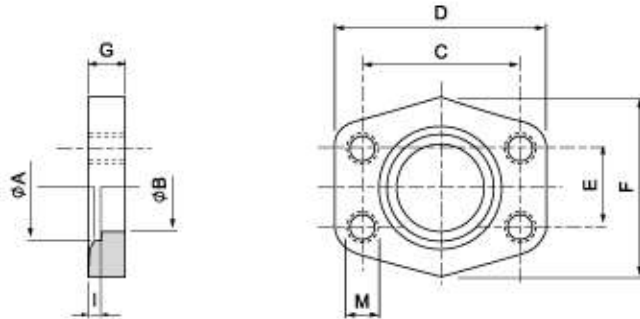

Maximum recommended working pressure kg/cm <sup>2</sup>	Nominal flange size, in	Type	Nominal pipe size	Dimensions								Screws	Weight kg	
				A	B	C	D	E	F	G	I			M
		<b>Standard Pressure</b>												
40	½"	SAGFC 08 SW	21.3 x 3.7	21.6	13	38.10	56	17.48	46	10	3	M 8	0.12	
40	¾"	SAGFC 12 SW	26.7 x 3.9	27.2	19	47.63	65	22.23	50	12	4	M 10	0.20	
40	1"	SAGFC 16 SW	33.4 x 4.5	34.0	25	52.37	70	26.19	55	12	4	M 10	0.25	
40	1¼"	SAGFC 20 SW	42.2 x 4.9	42.8	32	58.72	79	30.18	68	12	4	M 10	0.31	
40	1½"	SAGFC 24 SW	48.3 x 5.1	48.6	38	69.85	93	35.71	78	15	4	M 12	0.50	
40	2"	SAGFC 32 SW	60.3 x 5.5	61.0	51	77.77	102	42.88	90	15	4	M 12	0.59	
40	2½"	SAGFC 40 SW	73.0 x 7.0	73.5	63	88.90	114	50.80	105	15	4	M 12	0.72	
40	3"	SAGFC 48 SW	88.9 x 7.6	90.5	76	106.38	134	61.93	124	20	5	M 16	1.25	
40	3½"	SAGFC 56 SW	101.5 x 8.1	103.0	89	120.65	152	69.85	136	20	5	M 16	1.50	
40	4"	SAGFC 64 SW	114.3 x 8.6	115.0	102	130.18	162	77.77	146	25	6	M 16	2.15	
40	5"	SAGFC 80 SW	141.3 x 9.5	143.0	127	152.40	190	92.08	170	28	8	M 16	3.00	



# SAE J 518 C 61/62 Flanges

SAE - socket weld flange 500 psi - companion

## SADFC - SW

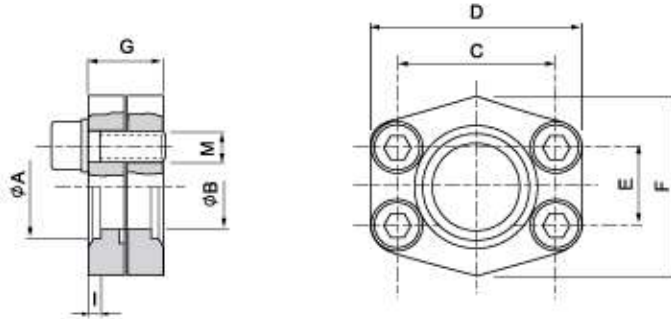

Maximum recommended working pressure kg/cm <sup>2</sup>	Nominal flange size, in	Type	Nominal pipe size	Dimensions								Screws	Weight kg
				A	B	C	D	E	F	G	I		
		<b>Standard Pressure</b>											
40	½"	SADFC 08 SW	21.3 x 3.7	21.6	13	38.10	56	17.48	46	10	3	M 8 x 25	0.24
40	¾"	SADFC 12 SW	26.7 x 3.9	27.2	19	47.63	65	22.23	50	12	4	M 10 x 30	0.40
40	1"	SADFC 16 SW	33.4 x 4.5	34.0	25	52.37	70	26.19	55	12	4	M 10 x 30	0.50
40	1 ¼"	SADFC 20 SW	42.2 x 4.9	42.8	32	58.72	79	30.18	68	12	4	M 10 x 30	0.62
40	1 ½"	SADFC 24 SW	48.3 x 5.1	48.6	38	69.85	93	35.71	78	15	4	M 12 x 35	1.00
40	2"	SADFC 32 SW	60.3 x 5.5	61.0	51	77.77	102	42.88	90	15	4	M 12 x 35	1.18
40	2 ½"	SADFC 40 SW	73.0 x 7.0	73.5	63	88.90	114	50.80	105	15	4	M 12 x 35	1.44
40	3"	SADFC 48 SW	88.9 x 7.6	90.5	76	106.38	134	61.93	124	20	5	M 16 x 40	2.50
40	3 ½"	SADFC 56 SW	101.5 x 8.1	103.0	89	120.65	152	69.85	136	20	5	M 16 x 40	3.00
40	4"	SADFC 64 SW	114.3 x 8.6	115.0	102	130.18	162	77.77	146	25	6	M 16 x 45	4.30
40	5"	SADFC 80 SW	141.3 x 9.5	143.0	127	152.40	190	92.08	170	28	8	M 16 x 45	6.00

# SAE J 518 C 61/62 Flanges

SAE - weld on flange

**SAAFS - BW**

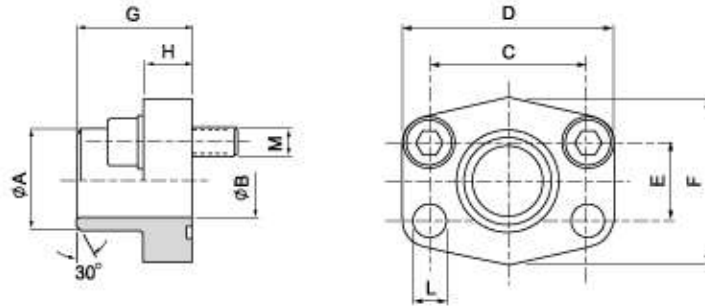

Maximum recommended working pressure kg/cm <sup>2</sup>	Nominal flange size, in	Type	Dimensions									Screws		Weight kg
			A	B	C	D	E	F	G	H	L	M		
												metr.	unc	
<b>Standard Pressure</b>														
350	½"	SAAFS 308-08 BBW	21.6	14	38.10	54	17.48	46	36	16	9.0	M 8 x 30	⅝ x 1¼	0.28
350	¾"	SAAFS 312-12 BBW	27.2	19	47.63	65	22.23	50	36	18	11.0	M 10 x 35	⅝ x 1½	0.39
350	1"	SAAFS 316-16 BBW	34.0	24	52.37	70	26.19	55	38	18	11.0	M 10 x 35	⅝ x 1½	0.46
280	1¼"	SAAFS 320-20 BBW	42.8	32	58.72	79	30.18	68	41	21	11.5	M 10 x 40	⅝ x 1½	0.66
210	1½"	SAAFS 324-24 BBW	48.6	38	69.85	93	35.71	78	45	25	13.5	M 12 x 45	⅝ x 1¾	1.05
210	2"	SAAFS 332-32 BBW	61.0	49	77.77	102	42.88	90	45	25	13.5	M 12 x 45	⅝ x 1¾	1.19
175	2½"	SAAFS 340-40 BBW	73.5	59	88.90	114	50.80	105	50	25	13.5	M 12 x 45	⅝ x 1¾	1.40
140	3"	SAAFS 348-48 BBW	90.5	74	106.38	134	61.93	124	50	27	17.0	M 16 x 50	⅝ x 2	2.15
35	3½"	SAAFS 356-56 BBW	103.0	85	120.65	152	69.85	136	48	27	17.0	M 16 x 50	⅝ x 2	2.40
35	4"	SAAFS 364-64 BBW	115.0	97	130.18	162	77.77	146	48	27	17.0	M 16 x 50	⅝ x 2	2.85
35	5"	SAAFS 380-80 BBW	143.0	120	152.40	184	92.08	180	50	28	17.0	M 16 x 55	⅝ x 2	5.20
<b>High Pressure</b>														
420	½"	SAAFS 608-08 CBW	21.6	12	40.49	54	18.24	46	36	16	9.0	M 8 x 30	⅝ x 1¼	0.29
420	¾"	SAAFS 612-12 CBW	27.2	16	50.80	71	23.80	55	35	21	11.0	M 10 x 35	⅝ x 1½	0.50
420	1"	SAAFS 616-16 CBW	34.0	21	57.15	79	27.76	68	41	21	12.5	M 12 x 45	⅝ x 1¾	0.76
414	1¼"	SAAFS 620-20 CBW	42.8	29	66.68	93	31.75	78	44	25	14.5	M 14 x 45	⅝ x 1¾	1.20
414	1½"	SAAFS 624-24 CBW	48.6	34	79.38	112	36.50	94	55	30	17.0	M 16 x 50	⅝ x 2	1.65
414	2"	SAAFS 632-32 CBW	61.0	43	96.82	134	44.45	114	65	37	21.0	M 20 x 65	⅝ x 2½	2.45
420	2½"	SAAFS 640-40 CBW	73.5	54	123.80	180	58.70	152	80	45	26.0	M 24 x 75	-	6.40

# SAE J 518 C 61/62 Flanges

SAE - weld on flange - companion

## SAGFS - BW

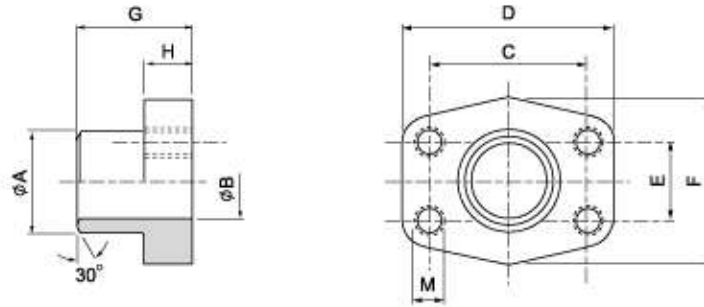

Maximum recommended working pressure kg/cm <sup>2</sup>	Nominal flange size, in	Type	Dimensions								Screws		Weight kg
			A	B	C	D	E	F	G	H	M		
											metr.	unc	
<b>Standard Pressure</b>													
350	½"	SAGFS 308-08 BBW	21.6	14	38.10	54	17.48	46	36	16	M 8	⅜	0.25
350	¾"	SAGFS 312-12 BBW	27.2	19	47.63	65	22.23	50	36	18	M 10	⅜	0.39
350	1"	SAGFS 316-16 BBW	34.0	24	52.37	70	26.19	55	38	18	M 10	⅜	0.46
280	1 ¼"	SAGFS 320-20 BBW	42.8	32	58.72	79	30.18	68	41	21	M 10	⅜	0.66
210	1 ½"	SAGFS 324-24 BBW	48.6	38	69.85	93	35.71	78	45	25	M 12	½	1.05
210	2"	SAGFS 332-32 BBW	61.0	49	77.77	102	42.88	90	45	25	M 12	½	1.19
175	2 ½"	SAGFS 340-40 BBW	73.5	59	88.90	114	50.80	105	50	25	M 12	½	1.40
140	3"	SAGFS 348-48 BBW	90.5	74	106.38	134	61.93	124	50	27	M 16	⅝	2.15
35	3 ½"	SAGFS 356-56 BBW	103.0	85	120.65	152	69.85	136	48	27	M 16	⅝	2.40
35	4"	SAGFS 364-64 BBW	115.0	97	130.18	162	77.77	146	48	27	M 16	⅝	2.85
35	5"	SAGFS 380-80 BBW	143.0	122	152.40	184	92.08	180	50	28	M 16	⅝	5.20
<b>High Pressure</b>													
420	½"	SAGFS 608-08 CBW	21.5	12	40.49	54	18.24	46	36	16	M 8	⅜	0.26
420	¾"	SAGFS 612-12 CBW	27.2	16	50.80	71	23.80	55	35	21	M 10	⅜	0.50
420	1"	SAGFS 616-16 CBW	34.0	21	57.15	79	27.76	68	41	21	M 12	⅜	0.76
420	1 ¼"	SAGFS 620-20 CBW	42.8	29	66.68	93	31.75	78	44	25	M 14	½	1.20
420	1 ½"	SAGFS 624-24 CBW	48.6	34	79.38	112	36.50	94	55	30	M 16	⅝	1.65
420	2"	SAGFS 632-32 CBW	61.0	43	96.82	134	44.45	114	65	37	M 20	¾	2.45
420	2 ½"	SAGFS 640-40 CBW	73.5	54	123.80	180	58.70	152	80	45	M 24	-	6.40



# SAE J 518 C 61/62 Flanges

SAE - weld on flange - pipe schedule 40.

## SAAFS - BW

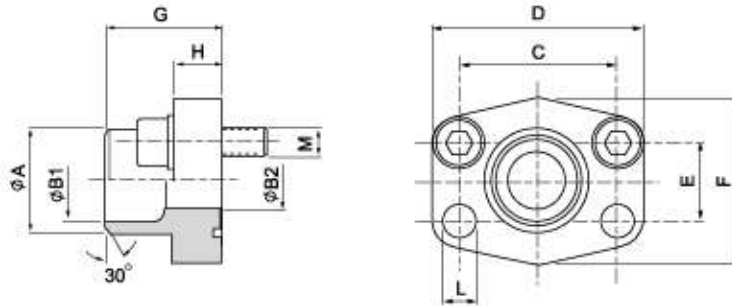

Maximum recommended working pressure kg/cm <sup>2</sup>	Nominal flange size, in	Type	Nominal pipe size	Dimensions										Screws		Weight kg	
				A	B <sub>1</sub>	B <sub>2</sub>	C	D	E	F	G	H	L	M			
														metr.	unc		
		<b>Standard Pressure</b>															
350	½"	SAAFS 308-08 ABW	21.3 x 2.7	21.6	16	13	38.10	54	17.48	46	35	16	9.0	M 8 x 30	⅝ x 1¼	0.28	
350	¾"	SAAFS 312-12 ABW	26.7 x 2.9	27.2	21	19	47.63	65	22.23	50	36	18	11.0	M 10 x 35	⅝ x 1½	0.39	
350	1"	SAAFS 316-16 ABW	33.4 x 3.4	34.0	27	25	52.37	70	26.19	55	38	18	11.0	M 10 x 35	⅝ x 1½	0.46	
280	1¼"	SAAFS 320-20 ABW	42.2 x 3.6	42.8	35	31	58.72	79	30.18	68	41	21	11.5	M 10 x 40	⅝ x 1½	0.66	
210	1½"	SAAFS 324-24 ABW	48.3 x 3.7	48.6	41	38	69.85	93	35.71	78	45	24.5	13.5	M 12 x 45	⅝ x 1¾	1.05	
210	2"	SAAFS 332-32 ABW	60.3 x 3.9	61.0	53	51	77.77	102	42.88	90	45	25	13.5	M 12 x 45	⅝ x 1¾	1.19	
175	2½"	SAAFS 340-40 ABW	73.0 x 3.9	73.5	65	63	88.90	114	50.80	105	50	25	13.5	M 12 x 45	⅝ x 1¾	1.40	
140	3"	SAAFS 348-48 ABW	88.9 x 5.2	90.5	79	76	106.38	134	61.93	124	51	26	17.0	M 16 x 50	⅝ x 2	2.15	
35	3½"	SAAFS 356-56 ABW	101.5 x 5.5	103.0	91	89	120.65	152	69.85	136	48	26	17.0	M 16 x 50	⅝ x 2	2.40	
35	4"	SAAFS 364-64 ABW	114.0 x 5.7	115.0	103	102	130.18	162	77.77	146	48	26	17.0	M 16 x 50	⅝ x 2	2.85	
35	5"	SAAFS 380-80 ABW	141.0 x 6.6	143.0	128	127	152.40	184	92.08	180	50	28	17.0	M 16 x 55	⅝ x 2	5.00	

# SAE J 518 C 61/62 Flanges

SAE - weld on flange - pipe schedule 40 - companion

## SAGFS - BW

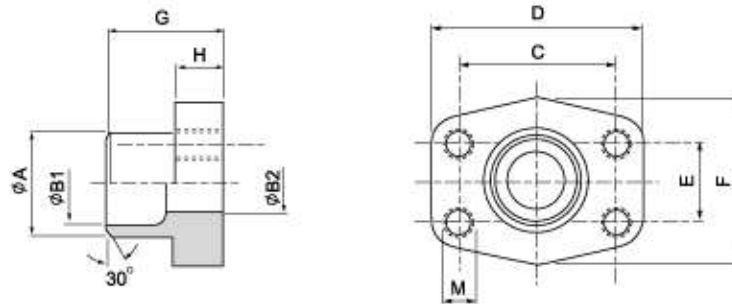

Maximum recommended working pressure kg/cm <sup>2</sup>	Nominal flange size, in	Type	Nominal pipe size	Dimensions									Screws M	Weight kg
				A	B <sub>1</sub>	B <sub>2</sub>	C	D	E	F	G	H		
		<b>Standard Pressure</b>												
350	½"	SAGFS 308-08 ABW	21.3 x 2.7	21.6	16	13	38.10	54	17.48	46	35	16	M 8	0.28
350	¾"	SAGFS 312-12 ABW	26.7 x 2.9	27.2	21	19	47.63	65	22.23	50	36	18	M 10	0.39
350	1"	SAGFS 316-16 ABW	33.4 x 3.4	34.0	27	25	52.37	70	26.19	55	38	18	M 10	0.46
280	1 ¼"	SAGFS 320-20 ABW	42.2 x 3.6	42.8	35	31	58.72	79	30.18	68	41	21	M 10	0.66
210	1 ½"	SAGFS 324-24 ABW	48.3 x 3.7	48.6	41	38	69.85	93	35.71	78	45	25	M 12	1.05
210	2"	SAGFS 332-32 ABW	60.3 x 3.9	61.0	53	51	77.77	102	42.88	90	45	25	M 12	1.19
175	2 ½"	SAGFS 340-40 ABW	73.0 x 3.9	73.5	65	63	88.90	114	50.80	105	50	25	M 12	1.40
140	3"	SAGFS 348-48 ABW	88.9 x 5.2	90.5	79	76	106.38	134	61.93	124	51	26	M 16	2.15
35	3 ½"	SAGFS 356-56 ABW	101.5 x 5.5	103.0	91	89	120.65	152	69.85	136	48	26	M 16	2.38
35	4"	SAGFS 364-64 ABW	114.0 x 5.7	115.0	103	102	130.18	162	77.77	146	48	26	M 16	2.85
35	5"	SAGFS 380-80 ABW	141.0 x 6.6	143.0	128	127	152.40	184	92.08	180	50	28	M 16	5.00

# SAE J 518 C 61/62 Flanges

SAE - weld on flange - metric tubes

## SAAFS - M

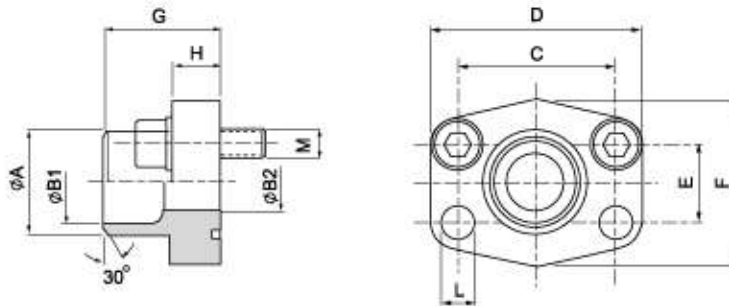

Maximum recommended working pressure kg/cm <sup>2</sup>	Nominal flange size, in	Type	Tube size	Dimensions										Screws		Weight kg
				A	B <sub>1</sub>	B <sub>2</sub>	C	D	E	F	G	H	L	M		
														metr.	unc	
<b>Standard Pressure</b>																
350	1/2"	SAAFS 308-20 M	20 x 3	20	14	14	38.10	54	17.48	46	35	16	9.0	M 8 x 30	5/16 x 1 1/4	0.28
350	1/2"	SAAFS 308-22 M	22 x 3	22	16	13	38.10	54	17.48	46	35	16	9.0	M 8 x 30	5/16 x 1 1/4	0.28
350	3/8"	SAAFS 312-25 M	25 x 3	25	19	19	47.63	65	22.23	50	36	18	11.0	M 10 x 35	3/8 x 1 1/2	0.39
350	3/8"	SAAFS 312-28 M	28 x 3	28	21.5	19	47.63	65	22.23	50	36	18	11.0	M 10 x 35	3/8 x 1 1/2	0.39
350	1"	SAAFS 316-30 M	30 x 4	30	22	22	52.37	70	26.19	55	38	18	11.0	M 10 x 35	3/8 x 1 1/2	0.46
350	1"	SAAFS 316-35 M	35 x 4	35	27	25	52.37	70	26.19	55	38	18	11.0	M 10 x 40	3/8 x 1 1/2	0.47
280	1 1/4"	SAAFS 320-38 M	38 x 4	38	30	30	58.72	79	30.18	68	41	21	11.5	M 10 x 40	3/8 x 1 1/2	0.66
280	1 1/4"	SAAFS 320-42 M	42 x 3	43	36	31	58.72	79	30.18	68	41	21	11.5	M 12 x 45	3/8 x 1 1/2	0.66
210	1 1/2"	SAAFS 324-38 M	38 x 4	38	30	30	69.85	93	35.71	78	45	25	13.5	M 12 x 45	1/2 x 1 3/4	1.05
210	1 1/2"	SAAFS 324-42 M	42 x 3	42	36	36	69.85	93	35.71	78	45	25	13.5	M 16 x 50	1/2 x 1 3/4	1.05
<b>High Pressure</b>																
420	1/2"	SAAFS 608-20 M	20 x 3	20	14	14	40.49	54	18.24	46	34	16	9.0	M 8 x 30	5/16 x 1 1/4	0.29
420	3/8"	SAAFS 612-20 M	20 x 3	20	14	14	50.80	71	23.80	55	35	21	11.0	M 10 x 35	3/8 x 1 1/2	0.50
420	3/8"	SAAFS 612-25 M	25 x 4	25	17	17	50.80	71	23.80	55	35	21	11.0	M 10 x 35	3/8 x 1 1/2	0.53
420	1"	SAAFS 616-25 M	25 x 4	25	17	17	57.15	81	27.76	65	42	25	12.5	M 12 x 45	3/8 x 1 1/2	0.76
420	1"	SAAFS 616-30 M	30 x 4	30	22	22	57.15	81	27.76	65	42	25	12.5	M 12 x 45	3/8 x 1 1/2	0.80
420	1 1/4"	SAAFS 620-30 M	30 x 4	30	22	22	66.68	95	31.75	78	44	25	14.5	M 14 x 45	1/2 x 1 3/4	1.20
420	1 1/4"	SAAFS 620-38 M	38 x 6	38	26	26	66.68	95	31.75	78	44	25	14.5	M 14 x 45	1/2 x 1 3/4	1.29
420	1 1/2"	SAAFS 624-38 M	38 x 6	38	26	26	79.38	112	36.50	94	56	28	17.0	M 16 x 50	1/2 x 2	1.52



# SAE J 518 C 61/62 Flanges

SAE - weld on flange - metric tubes - companion

## SAGFS - M

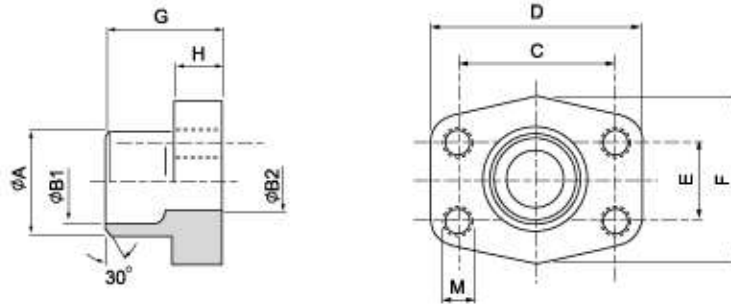

Maximum recommended working pressure kg/cm <sup>2</sup>	Nominal flange size, in	Type	Dimensions										Weight kg	
			A	B <sub>1</sub>	B <sub>2</sub>	C	D	E	F	G	H	M		
<b>Standard Pressure</b>														
350	½"	SAGFS 308-20 M	20 x 3	20	14	14	38.10	54	17.48	46	35.0	16	M 8	0.28
350	½"	SAGFS 308-22 M	22 x 3	22	16	13	38.10	54	17.48	46	35.0	16	M 8	0.28
350	¾"	SAGFS 312-25 M	25 x 3	25	19	19	47.63	65	22.23	50	36.0	18	M 10	0.39
350	¾"	SAGFS 312-28 M	28 x 3	28	22	19	47.63	65	22.23	50	36.0	18	M 10	0.39
350	1"	SAGFS 316-30 M	30 x 4	30	22	22	52.37	70	26.19	55	38.0	18	M 10	0.46
350	1"	SAGFS 316-35 M	35 x 4	35	27	25	52.37	70	26.19	55	38.0	18	M 10	0.47
280	1½"	SAGFS 320-38 M	38 x 4	38	30	30	58.72	79	30.18	68	41.0	21	M 10	0.66
280	1½"	SAGFS 320-42 M	42 x 3	43	36	31	58.72	79	30.18	68	41.0	21	M 10	0.66
210	1½"	SAGFS 324-38 M	38 x 4	38	30	30	69.85	93	35.71	78	44.5	25	M 12	1.05
210	1½"	SAGFS 324-42 M	42 x 3	42	36	36	69.85	93	35.71	78	44.5	25	M 12	1.05
<b>High Pressure</b>														
420	½"	SAGFS 608-20 M	20 x 3	20	14	14	40.49	54	18.24	46	34.0	16	M 8	0.29
420	¾"	SAGFS 612-20 M	20 x 3	20	14	14	50.80	71	23.80	55	35.0	21	M 10	0.50
420	¾"	SAGFS 612-25 M	25 x 4	25	17	17	50.80	71	23.80	55	35.0	21	M 10	0.53
420	1"	SAGFS 616-25 M	25 x 4	25	17	17	57.15	81	27.76	65	42.0	25	M 12	0.76
420	1"	SAGFS 616-30 M	30 x 4	30	22	22	57.15	81	27.76	65	42.0	25	M 12	0.80
420	1½"	SAGFS 620-30 M	30 x 4	30	22	22	66.68	95	31.75	78	44.0	25	M 12	1.20
420	1½"	SAGFS 620-38 M	38 x 6	38	26	26	66.68	95	31.75	78	44.0	25	M 12	1.29
420	1½"	SAGFS 624-38 M	38 x 6	38	26	26	79.38	112	36.50	94	56.0	28	M 16	1.52

# SAE J 518 C 61/62 Flanges

SAE - welding head

**SASFH - BW**

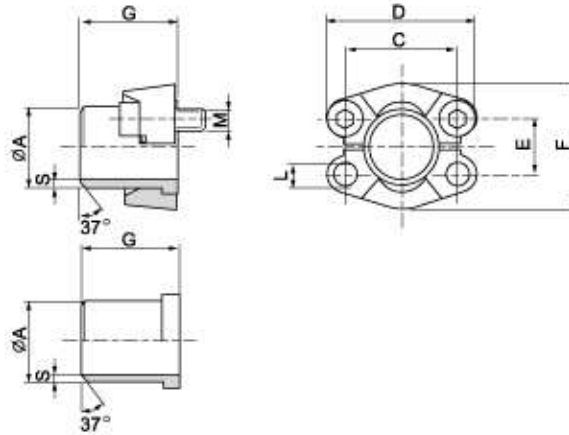

Maximum recommended working pressure kg/cm <sup>2</sup>	Nominal flange size, in	Type	Dimensions							Screws		Weight kg
			Pipe size A x S	C	D	E	F	G	L	M		
										metr.	unc	
<b>Standard Pressure</b>												
350	½"	SASFS 308-08 BW	21.3 x 3.7	38.10	54	17.48	45.6	41	9.0	M 8 x 25	⅝ x 1½	0.08
350	¾"	SASFS 312-12 BW	26.7 x 3.9	47.63	65	22.23	51.8	50	11.0	M 10 x 30	⅝ x 1½	0.16
350	1"	SASFS 316-16 BW	33.4 x 4.5	52.37	70	26.19	58.4	50	11.0	M 10 x 30	⅝ x 1½	0.23
280	1½"	SASFS 320-20 BW	42.2 x 4.9	58.72	79	30.18	72.6	55	11.5	M 10 x 30	⅝ x 1½	0.30
210	1½"	SASFS 324-24 BW	48.3 x 5.1	69.85	94	35.71	82.2	57	13.5	M 12 x 35	⅝ x 1½	0.40
210	2"	SASFS 332-32 BW	60.3 x 5.5	77.77	102	42.88	96.4	57	13.5	M 12 x 35	⅝ x 1½	0.50
175	2½"	SASFS 340-40 BW	73.0 x 7.0	88.90	114	50.80	108.2	58	13.5	M 12 x 40	⅝ x 1½	0.80
140	3"	SASFS 348-48 BW	88.9 x 7.6	106.38	135	61.93	130.6	58	17.0	M 16 x 45	⅝ x 2	1.10
35	3½"	SASFS 356-56 BW	101.5 x 8.1	120.65	152	69.85	139.0	60	17.0	M 16 x 45	⅝ x 2	1.40
35	4"	SASFS 364-64 BW	114.3 x 8.6	130.18	162	77.77	152.0	60	17.0	M 16 x 50	⅝ x 2	1.75
35	5"	SASFS 380-80 BW	141.3 x 9.5	152.40	184	92.08	180.0	60	17.0	M 16 x 50	⅝ x 2	2.62
<b>High Pressure</b>												
420	½"	SASFS 608-08 BW	21.3 x 4.7	40.49	56	18.24	47.2	34	9.0	M 8 x 30	⅝ x 1½	0.08
420	¾"	SASFS 612-12 BW	26.7 x 5.5	50.80	71	23.80	60.0	38	11.0	M 10 x 35	⅝ x 1½	0.17
420	1"	SASFS 616-16 BW	33.4 x 6.4	57.15	81	27.76	69.6	40	12.5	M 12 x 45	⅝ x 1½	0.25
420	1½"	SASFS 620-20 BW	42.2 x 6.4	66.68	95	31.75	77.2	45	14.5	M 14 x 50	⅝ x 1½	0.30
420	1½"	SASFS 624-24 BW	48.3 x 7.1	79.38	113	36.50	95.0	50	17.0	M 16 x 55	⅝ x 2	0.53
420	2"	SASFS 632-32 BW	60.3 x 8.7	96.82	133	44.45	113.8	58	21.0	M 20 x 65	⅝ x 2½	0.90
420	2½"	SASFS 640-40 BW	73.0 x 9.5	123.80	180	58.80	150.2	75	26.0	M 24 x 75	-	2.40
420	3"	SASFS 648-48 BW	88.9 x 11.1	152.40	215	71.60	198.2	80	31.0	M 30 x 90	-	3.60



# SAE J 518 C 61/62 Flanges

SAE - welding head - coupling

**SADFH - BW**

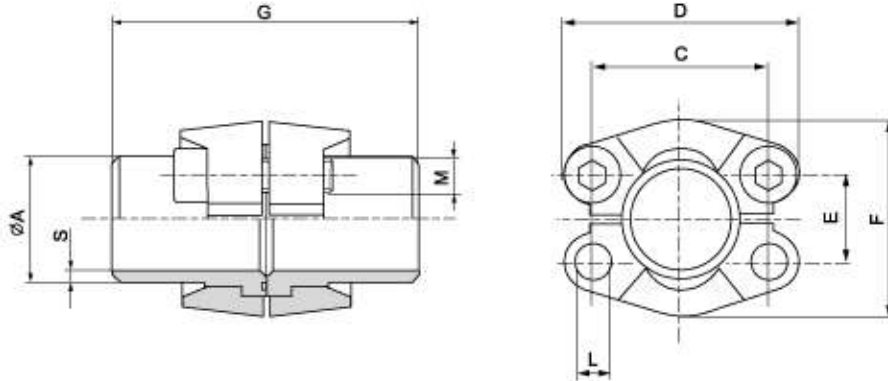

Maximum recommended working pressure kg/cm <sup>2</sup>	Nominal flange size, in	Type	Dimensions							Screws		Weight kg
			Pipe size A x S	C	D	E	F	G	L	M		
										metr.	unc	
<b>Standard Pressure</b>												
350	1/2"	SADFS 308-08 BW	21.3 x 3.7	38.10	54	17.48	45.6	82	9.0	M 8 x 25	3/16 x 1 1/4	0.50
350	3/8"	SADFS 312-12 BW	26.7 x 3.9	47.63	65	22.23	51.8	100	11.0	M 10 x 30	3/8 x 1 1/4	0.80
350	1"	SADFS 316-16 BW	33.4 x 4.5	52.37	70	26.19	58.4	100	11.0	M 10 x 30	3/8 x 1 1/4	1.10
280	1 1/8"	SADFS 320-20 BW	42.2 x 4.9	58.72	79	30.18	72.6	110	11.5	M 10 x 30	3/8 x 1 1/2	1.50
210	1 1/2"	SADFS 324-24 BW	48.3 x 5.1	69.85	94	35.71	82.2	114	13.5	M 12 x 35	1/2 x 1 1/2	2.20
210	2"	SADFS 332-32 BW	60.3 x 5.5	77.77	102	42.88	96.4	114	13.5	M 12 x 35	1/2 x 1 1/2	2.40
175	2 1/2"	SADFS 340-40 BW	73.0 x 7.0	88.90	114	50.80	108.2	116	13.5	M 12 x 40	1/2 x 1 3/4	3.50
140	3"	SADFS 348-48 BW	88.9 x 7.6	106.38	135	61.93	130.6	116	17.0	M 16 x 45	3/4 x 2	5.30
35	3 1/2"	SADFS 356-56 BW	101.5 x 8.1	120.65	152	69.85	139.0	120	17.0	M 16 x 45	3/4 x 2	5.30
35	4"	SADFS 364-64 BW	114.3 x 8.6	130.18	162	77.77	152.0	120	17.0	M 16 x 50	3/4 x 2	7.50
35	5"	SADFS 380-80 BW	141.3 x 9.5	152.40	184	92.08	180.0	120	17.0	M 16 x 50	3/4 x 2	11.0
<b>High Pressure</b>												
420	1/2"	SADFS 608-08 BW	21.3 x 4.7	40.49	56	18.24	47.2	34	9.0	M 8 x 30	3/16 x 1 1/4	0.08
420	3/8"	SADFS 612-12 BW	26.7 x 5.5	50.80	71	23.80	60.0	38	11.0	M 10 x 35	3/8 x 1 1/2	0.17
420	1"	SADFS 616-16 BW	33.4 x 6.4	57.15	81	27.76	69.6	40	12.5	M 12 x 45	3/8 x 1 3/4	0.25
420	1 1/8"	SADFS 620-20 BW	42.2 x 6.4	66.68	95	31.75	77.2	45	14.5	M 14 x 50	1/2 x 1 3/4	0.30
420	1 1/2"	SADFS 624-24 BW	48.3 x 7.1	79.38	113	36.50	95.0	50	17.0	M 16 x 55	3/8 x 2	0.53
420	2"	SADFS 632-32 BW	60.3 x 8.7	96.82	133	44.45	113.8	58	21.0	M 20 x 65	1/2 x 2 1/2	0.90
420	2 1/2"	SADFS 640-40 BW	73.0 x 9.5	123.80	180	58.80	150.2	75	26.0	M 24 x 75	-	2.40
420	3"	SADFS 648-48 BW	88.9 x 11.1	152.40	215	71.60	198.2	80	31.0	M 30 x 90	-	3.60



# SAE J 518 C 61/62 Flanges

SAE - Welding neck hub

SAEWNA

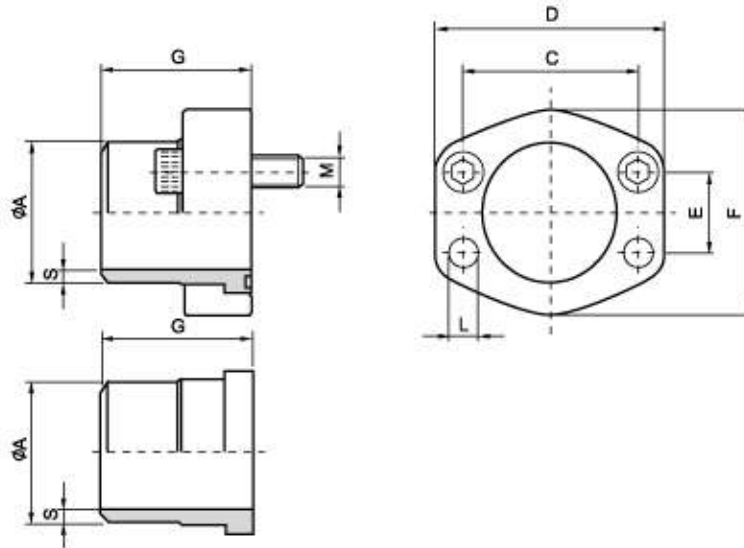

Maximum recommended working pressure kg/cm <sup>2</sup>	Nominal flange size, in	Type	Dimensions							Screws		Weight kg
			Pipe size A x S	C	D	E	F	G	L	M		
										metr.	unc	
<b>Standard Pressure</b>												
350	½"	SAEWNA04-04B-61	21.3 x 3.7	38.10	54	17.48	45.6	50	9.0	M 8 x 35	⅜ x 1½	0.08
350	¾"	SAEWNA06-06B-61	26.7 x 3.9	47.63	65	22.23	51.8	50	11.0	M 10 x 35	⅜ x 1½	0.16
350	1"	SAEWNA08-08B-61	33.4 x 4.5	52.37	70	26.19	58.4	50	11.0	M 10 x 35	⅜ x 1½	0.23
280	1¼"	SAEWNA10-10B-61	42.2 x 4.9	58.72	79	30.18	72.6	55	11.5	M 12 x 45	⅜ x 1½	0.30
280	1½"	SAEWNA12-12B-61	48.3 x 5.1	69.85	94	35.71	82.2	60	13.5	M 12 x 45	½ x 1½	0.40
280	2"	SAEWNA16-16B-61	60.3 x 5.5	77.77	102	42.88	96.4	60	13.5	M 12 x 50	½ x 1½	0.50
210	2½"	SAEWNA20-20B-61	73.0 x 7.0	88.90	114	50.80	108.2	60	13.5	M 12 x 60	½ x 1½	0.80
210	3"	SAEWNA24-24B-61	88.9 x 7.6	106.38	135	61.93	130.6	60	17.0	M 16 x 70	⅝ x 2	1.10
160	3½"	SAEWNA28-28B-61	101.5 x 8.1	120.65	152	69.85	139.0	60	17.0	M 16 x 50	⅝ x 2	1.40
160	4"	SAEWNA32-32B-61	114.3 x 8.6	130.18	162	77.77	152.0	60	17.0	M 16 x 60	⅝ x 2	1.75
35	5"	SAEWNA40-40B-61	141.3 x 9.5	152.40	184	92.08	180.0	60	17.0	M 16 x 70	⅝ x 2	2.62
<b>High Pressure</b>												
420	½"	SAEWNA04-04C-62	21.3 x 4.7	40.49	56	18.24	47.2	50	9.0	M 8 x 35	⅜ x 1½	0.08
420	¾"	SAEWNA06-06C-62	26.7 x 5.5	50.80	71	23.80	60.0	50	11.0	M 10 x 40	⅜ x 1½	0.17
420	1"	SAEWNA08-08C-62	33.4 x 6.4	57.15	81	27.76	69.6	50	13.0	M 12 x 45	⅜ x 1½	0.25
420	1¼"	SAEWNA10-10C-62	42.2 x 6.4	66.68	95	31.75	77.2	55	14.5	M 14 x 50	½ x 1½	0.30
420	1½"	SAEWNA12-12C-62	48.3 x 7.1	79.38	113	36.50	95.0	60	17.0	M 16 x 60	⅜ x 2	0.53
420	2"	SAEWNA16-16C-62	60.3 x 8.7	96.82	133	44.45	113.8	60	21.0	M 20 x 70	⅜ x 2½	0.90
420	2½"	SAEWNA20-20C-62	73.0 x 9.5	123.80	180	58.80	150.2	60	26.0	M 24 x 75	-	2.40
420	3"	SAEWNA24-24C-62	88.9 x 11.1	152.40	215	71.60	198.2	60	31.0	M 30 x 90	-	3.60

# SAE J 518 C 61/62 Flanges

SAE - Welding neck coupling

## SAEWNC

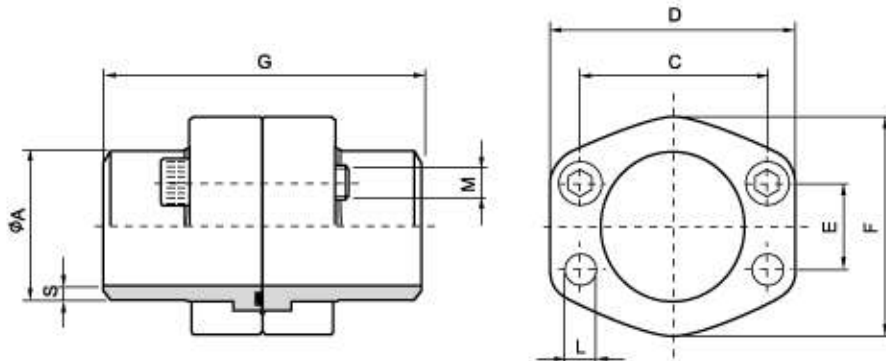

Maximum recommended working pressure kg/cm <sup>2</sup>	Nominal flange size, in	Type	Dimensions							Screws		Weight kg
			Pipe size A x S	C	D	E	F	G	L	M		
										metr.	unc	
<b>Standard Pressure</b>												
350	½"	SAEWNC04-04B-61	21.3 x 3.7	38.10	54	17.48	45.6	100	9.0	M 8 x 35	⅜ x 1½	0.08
350	¾"	SAEWNC06-06B-61	26.7 x 3.9	47.63	65	22.23	51.8	100	11.0	M 10 x 35	⅜ x 1½	0.16
350	1"	SAEWNC08-08B-61	33.4 x 4.5	52.37	70	26.19	58.4	100	11.0	M 10 x 35	⅜ x 1½	0.23
280	1¼"	SAEWNC10-10B-61	42.2 x 4.9	58.72	79	30.18	72.6	110	11.5	M 12 x 45	⅜ x 1½	0.30
280	1½"	SAEWNC12-12B-61	48.3 x 5.1	69.85	94	35.71	82.2	120	13.5	M 12 x 45	½ x 1½	0.40
280	2"	SAEWNC16-16B-61	60.3 x 5.5	77.77	102	42.88	96.4	120	13.5	M 12 x 50	½ x 1½	0.50
210	2½"	SAEWNC20-20B-61	73.0 x 7.0	88.90	114	50.80	108.2	120	13.5	M 12 x 60	½ x 1½	0.80
210	3"	SAEWNC24-24B-61	88.9 x 7.6	106.38	135	61.93	130.6	120	17.0	M 16 x 70	⅝ x 2	1.10
160	3½"	SAEWNC28-28B-61	101.5 x 8.1	120.65	152	69.85	139.0	120	17.0	M 16 x 50	⅝ x 2	1.40
160	4"	SAEWNC32-32B-61	11.43 x 8.6	130.18	162	77.77	152.0	120	17.0	M 16 x 60	⅝ x 2	1.75
35	5"	SAEWNC40-40B-61	141.3 x 9.5	152.40	184	92.08	180.0	120	17.0	M 16 x 70	⅝ x 2	2.62
<b>High Pressure</b>												
420	½"	SAEWNC04-04C-62	21.3 x 4.7	40.49	56	18.24	47.2	100	9.0	M 8 x 35	⅜ x 1½	0.08
420	¾"	SAEWNC06-06C-62	26.7 x 5.5	50.80	71	23.80	60.0	100	11.0	M 10 x 40	⅜ x 1½	0.17
420	1"	SAEWNC08-08C-62	33.4 x 6.4	57.15	81	27.76	69.6	100	13.0	M 12 x 45	⅜ x 1½	0.25
420	1¼"	SAEWNC10-10C-62	42.2 x 6.4	66.68	95	31.75	77.2	110	14.5	M 14 x 50	½ x 1½	0.30
420	1½"	SAEWNC12-12C-62	48.3 x 7.1	79.38	113	36.50	95.0	120	17.0	M 16 x 60	⅝ x 2	0.53
420	2"	SAEWNC16-16C-62	60.3 x 8.7	96.82	133	44.45	113.8	120	21.0	M 20 x 70	¾ x 2½	0.90
420	2½"	SAEWNC20-20C-62	73.0 x 9.5	123.80	180	58.80	150.2	120	26.0	M 24 x 75	-	2.40
420	3"	SAEWNC24-24C-62	88.9 x 11.1	152.40	215	71.60	198.2	120	31.0	M 30 x 90	-	3.60



# SAE J 518 C 61/62 Flanges

SAE - weld on coupling

**SADFS - BW**

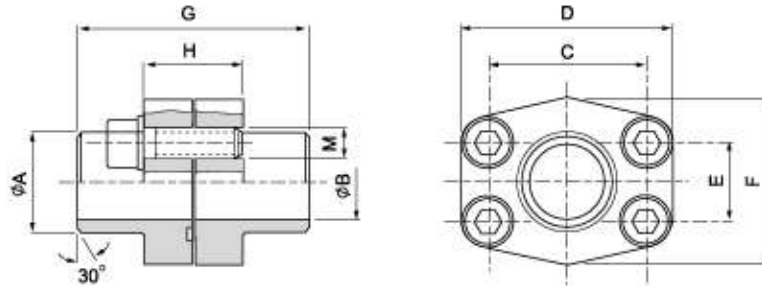

Maximum recommended working pressure kg/cm <sup>2</sup>	Nominal flange size, in	Type	Dimensions								Screws		Weight kg
			A	B	C	D	E	F	G	H	M		
											metr.	unc	
<b>Standard Pressure</b>													
350	½"	SADFS 308-08 BW	21.6	13	38.10	54	17.48	46	72	32	M 8 x 30	⅝ x 1½	0.56
350	¾"	SADFS 312-12 BW	27.2	19	47.63	65	22.23	50	72	36	M 10 x 35	⅝ x 1½	0.78
350	1"	SADFS 316-16 BW	34.0	25	52.37	70	26.19	55	76	36	M 10 x 35	⅝ x 1½	0.92
280	1½"	SADFS 320-20 BW	42.8	32	58.72	79	30.18	68	82	42	M 10 x 40	⅝ x 1½	1.32
210	1½"	SADFS 324-24 BW	48.6	38	69.85	93	35.71	78	88	50	M 12 x 45	⅝ x 1½	2.10
210	2"	SADFS 332-32 BW	61.0	51	77.77	102	42.88	90	90	50	M 12 x 45	⅝ x 1½	2.38
175	2½"	SADFS 340-40 BW	73.5	63	88.90	114	50.80	105	100	50	M 12 x 45	⅝ x 1½	2.80
140	3"	SADFS 348-48 BW	90.5	76	106.38	134	61.93	124	100	54	M 16 x 50	⅝ x 2	4.30
35	3½"	SADFS 356-56 BW	103.0	89	120.65	152	69.85	136	96	54	M 16 x 50	⅝ x 2	4.80
35	4"	SADFS 364-64 BW	115.0	102	130.18	162	77.77	146	96	54	M 16 x 50	⅝ x 2	5.70
35	5"	SADFS 380-80 BW	143.0	127	152.40	184	92.08	180	100	56	M 16 x 55	⅝ x 2	10.00
<b>High Pressure</b>													
420	½"	SADFS 608-08 BW	21.6	13	40.49	54	18.24	46	72	32	M 8 x 30	⅝ x 1½	0.56
420	¾"	SADFS 612-12 BW	27.2	19	50.80	71	23.80	55	70	42	M 10 x 35	⅝ x 1½	0.78
420	1"	SADFS 616-16 BW	34.0	25	57.15	79	27.76	68	82	42	M 12 x 45	⅝ x 1½	0.92
420	1½"	SADFS 620-20 BW	42.8	32	66.68	95	31.75	78	88	48	M 14 x 45	⅝ x 1½	1.32
420	1½"	SADFS 624-24 BW	48.6	38	79.38	114	36.50	94	110	60	M 16 x 50	⅝ x 2	2.38
420	2"	SADFS 632-32 BW	61.0	51	96.82	134	44.45	114	130	74	M 20 x 65	⅝ x 2½	4.30
420	2½"	SADFS 640-40 BW	73.5	61	123.80	180	58.70	152	160	90	M 24 x 75	-	5.70



# SAE J 518 C 61/62 Flanges

SAE - closed flange

## SA AFC

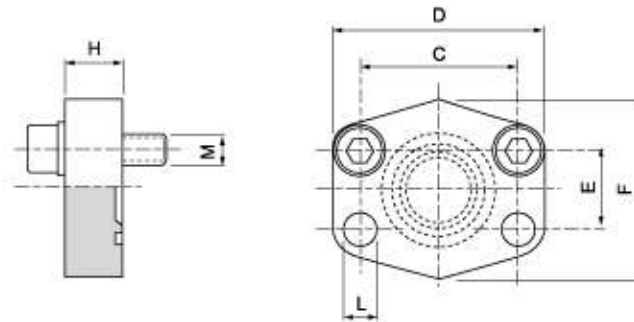

Maximum recommended working pressure kg/cm <sup>2</sup>	Nominal flange size, in	Type	Dimensions						Screws		Weight kg
			C	D	E	F	H	L	M		
									metr.	unc.	
		<b>Standard Pressure</b>									
350	½"	SA AFC 308	38.10	56	17.48	48	16	9.0	M 8 x 30	⅜ x 1½	0.20
350	¾"	SA AFC 312	47.63	65	22.23	50	16	11.0	M 10 x 35	⅜ x 1½	0.30
350	1"	SA AFC 316	52.37	70	26.19	60	19	11.0	M 10 x 35	⅜ x 1½	0.37
280	1¼"	SA AFC 320	58.72	79	30.18	68	18	11.5	M 10 x 40	⅜ x 1½	0.54
210	1½"	SA AFC 324	69.85	93	35.71	78	20	13.5	M 12 x 45	½ x 1¾	0.90
210	2"	SA AFC 332	77.77	102	42.88	90	20	13.5	M 12 x 45	½ x 1¾	1.00
175	2½"	SA AFC 340	88.90	114	50.80	105	20	13.5	M 12 x 45	½ x 1¾	1.35
140	3"	SA AFC 348	106.38	134	61.93	124	24	17.0	M 16 x 50	⅝ x 2	2.35
35	3½"	SA AFC 356	120.65	152	69.85	136	22	17.0	M 16 x 50	⅝ x 2	2.90
35	4"	SA AFC 364	130.18	162	77.77	146	25	17.0	M 16 x 50	⅝ x 2	3.90
35	5"	SA AFC 380	152.40	190	92.08	170	28	17.0	M 16 x 50	⅝ x 2	4.00
		<b>High Pressure</b>									
420	½"	SA AFC 608	40.49	56	18.24	48	16	9.0	M 8 x 30	⅜ x 1½	0.20
420	¾"	SA AFC 612	50.80	71	23.80	60	19	11.0	M 10 x 35	⅜ x 1½	0.48
420	1"	SA AFC 616	57.15	81	27.76	70	24	12.5	M 12 x 45	⅜ x 1¾	0.77
420	1¼"	SA AFC 620	66.68	95	31.75	78	27	14.5	M 14 x 45	½ x 1¾	0.85
420	1½"	SA AFC 624	79.38	112	36.50	94	30	17.0	M 16 x 50	⅝ x 2	1.80
420	2"	SA AFC 632	96.82	134	44.45	114	28	21.0	M 20 x 65	¾ x 2½	2.00
420	2½"	SA AFC 640	123.80	180	58.70	150	45	26.0	M 24 x 75	-	5.30

# SAE J 518 C 61/62 Flanges

SAE - closed flange companion

**SAAFG**

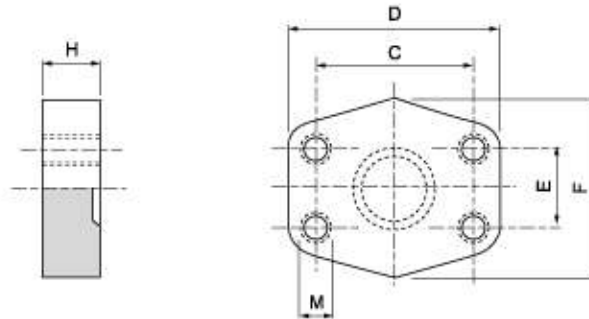

Maximum recommended working pressure kg/cm <sup>2</sup>	Nominal flange size, in	Type	Dimensions						Weight kg
			C	D	E	F	H	M	
		<b>Standard Pressure</b>							
350	½"	SAGFC 308	38.10	56	17.48	48	16	M 8	0.20
350	¾"	SAGFC 312	47.63	65	22.23	60	16	M 10	0.30
350	1"	SAGFC 316	52.37	70	26.19	60	19	M 10	0.37
280	1¼"	SAGFC 320	58.72	79	30.18	68	18	M 10	0.54
210	1½"	SAGFC 324	69.85	93	35.71	78	20	M 12	0.90
210	2"	SAGFC 332	77.77	102	42.88	90	20	M 12	1.00
175	2½"	SAGFC 340	88.90	114	50.80	105	20	M 12	1.35
140	3"	SAGFC 348	106.38	134	61.93	124	24	M 16	2.35
35	3½"	SAGFC 356	120.65	152	69.85	136	22	M 16	2.90
35	4"	SAGFC 364	130.18	162	77.77	146	25	M 16	3.90
35	5"	SAGFC 380	152.40	190	92.08	170	28	M 16	4.00
		<b>High Pressure</b>							
420	½"	SAGFC 608	40.49	56	18.24	48	16	M 8	0.20
420	¾"	SAGFC 612	50.80	71	23.80	60	19	M 10	0.48
420	1"	SAGFC 616	57.15	81	27.76	70	24	M 12	0.77
420	1¼"	SAGFC 620	66.68	95	31.75	78	27	M 14	0.85
420	1½"	SAGFC 624	79.38	112	36.50	94	30	M 16	1.80
420	2"	SAGFC 632	96.82	134	44.45	114	28	M 20	2.00
420	2½"	SAGFC 640	123.80	180	58.80	150	45	M 24	5.30

# SAE J 518 C 61/62 Flanges

## SAE - flange plug SABSO / BS

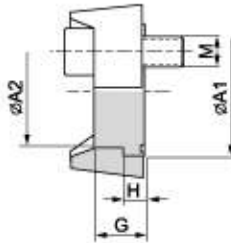

BSO

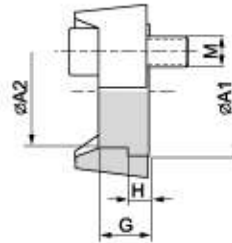

BS

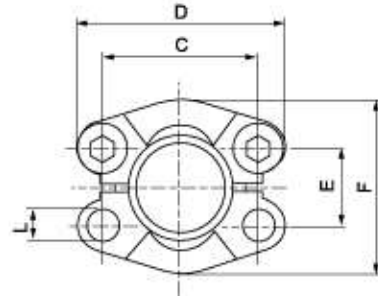

Maximum recommended working pressure kg/cm <sup>2</sup>	Nominal flange size, in	Type	Dimensions									Screws		Weight kg	
			A1	A2	C	D	E	F	G	H	L	M			
													metr.		unc
<b>Standard Pressure</b>															
350	½"	SA/BSO 308	30.2	23.9	38.10	54	17.48	45.6	16	6.9	9.0	M 8 x 25	⅝ x 1½	0.18	
350	¾"	SA/BSO 312	38.1	31.7	47.63	65	22.23	51.8	17	6.9	11.0	M 10 x 30	⅝ x 1½	0.20	
350	1"	SA/BSO 316	44.4	38.1	52.37	70	26.19	58.4	17	8.1	11.0	M 10 x 30	⅝ x 1½	0.26	
280	1½"	SA/BSO 320	50.8	42.3	58.72	79	30.18	72.6	17	8.1	11.5	M 10 x 30	⅝ x 1½	0.36	
210	1½"	SA/BSO 324	60.3	50.3	69.85	93	35.71	82.2	19	8.1	13.5	M 12 x 35	⅝ x 1½	0.54	
210	2"	SA/BSO 332	71.4	62.2	77.77	102	42.88	96.4	19	9.7	13.5	M 12 x 35	⅝ x 1½	0.60	
175	2½"	SA/BSO 340	84.1	74.0	88.90	114	50.80	108.0	40	9.5	13.5	M 12 x 35	⅝ x 1½	0.87	
140	3"	SA/BSO 348	101.6	90.0	106.38	135	61.93	130.6	45	9.5	17.0	M 16 x 50	⅝ x 2	1.56	
35	3½"	SA/BSO 356	114.3	102.0	120.65	152	69.85	139.0	30	11.2	17.0	M 16 x 50	⅝ x 2	1.80	
35	4"	SA/BSO 364	127.0	114.0	130.18	162	77.77	152.0	36	11.2	17.0	M 16 x 50	⅝ x 2	1.98	
35	5"	SA/BSO 380	152.4	140.0	152.40	184	92.08	180.0	45	11.2	17.0	M 16 x 50	⅝ x 2	3.00	
<b>High Pressure</b>															
420	½"	SA/BSO 608	31.7	23.9	40.49	56	18.24	47.2	18	7.9	9.0	M 8 x 30	⅝ x 1½	0.19	
420	¾"	SA/BSO 612	41.3	31.7	50.80	71	23.80	60.0	15	8.9	11.0	M 10 x 35	⅝ x 1½	0.42	
420	1"	SA/BSO 616	47.6	38.1	57.15	81	27.76	69.6	16	9.7	12.5	M 12 x 45	⅝ x 1½	0.64	
420	1½"	SA/BSO 620	54.0	43.7	66.68	95	31.75	77.2	16	10.4	14.5	M 14 x 50	⅝ x 1½	0.96	
420	1½"	SA/BSO 624	63.5	50.8	79.38	113	36.50	95.0	19	12.7	17.0	M 16 x 55	⅝ x 2	1.62	
420	2"	SA/BSO 632	79.4	66.5	96.82	133	44.45	113.8	30	12.7	21.0	M 20 x 65	⅝ x 2½	2.52	
420	2½"	SA/BSO 640	108.0	90.0	123.80	180	58.70	150.2	45	21.2	26.0	M 24 x 75	-	4.92	
420	3"	SA/BSO 648	132.0	114.0	152.40	215	71.60	198.16	55	26.5	31.0	M 30 x 90	-	10.32	



# SAE J 518 C 61/62 Flanges

SAE - flange head

**SAFT**

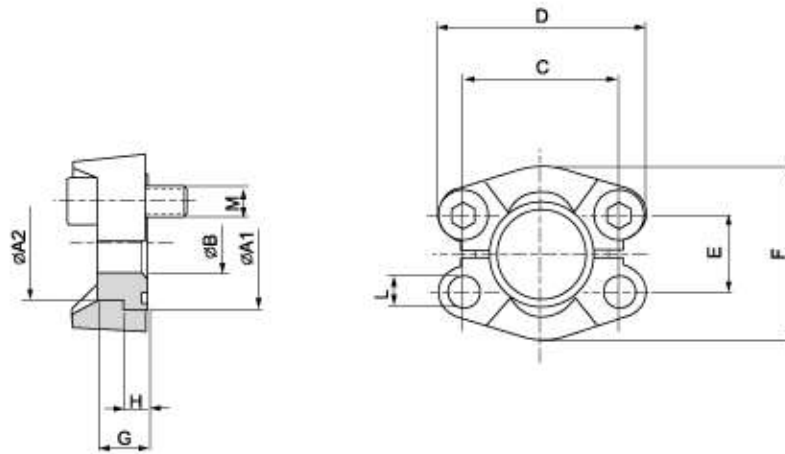

Maximum recommended working pressure kg/cm <sup>2</sup>	Nominal flange size, in	Type	Dimensions										Screws		Weight kg	
			A1	A2	B	C	D	E	F	G	H	L	M			
													metr.	unc.		
		<b>Standard Pressure</b>														
350	½"	SAFT 308	30.2	23.9	0/10	38.10	54	17.48	45.6	16	6.9	9.0	M 8 x 25	⅜ x 1½	0.17	
350	¾"	SAFT 312	38.1	31.7	0/15	47.63	65	22.23	51.8	17	6.9	11.0	M 10 x 30	⅜ x 1½	0.19	
350	1"	SAFT 316	44.4	38.1	0/20	52.37	70	26.19	58.4	17	8.1	11.0	M 10 x 30	⅜ x 1½	0.25	
280	1½"	SAFT 320	50.8	43.2	0/27	58.72	79	30.18	72.6	17	8.1	11.5	M 10 x 30	⅜ x 1½	0.35	
210	1½"	SAFT 324	60.3	50.3	0/32	69.85	94	35.71	82.2	19	8.1	13.5	M 12 x 35	½ x 1½	0.53	
210	2"	SAFT 332	71.4	62.2	0/40	77.77	102	42.88	96.4	19	9.7	13.5	M 12 x 35	½ x 1½	0.59	
175	2½"	SAFT 340	84.1	74.0	0/50	88.90	114	50.80	108.2	30	9.7	13.5	M 12 x 35	½ x 1½	0.86	
		<b>High Pressure</b>														
420	½"	SAFT 608	31.7	23.9	0/10	40.49	56	18.24	47.2	16	7.9	8.5	M 8 x 30	⅜ x 1½	0.18	
420	¾"	SAFT 612	41.3	31.7	0/15	50.80	71	23.80	60	20	8.9	10.5	M 10 x 35	⅜ x 1½	0.41	
420	1"	SAFT 616	47.6	38.1	0/20	57.15	81	27.76	69.6	22	9.7	12.5	M 12 x 45	⅜ x 1½	0.63	
420	1½"	SAFT 620	54.0	43.7	0/27	66.88	95	31.75	77.2	27	10.4	14.5	M 14 x 50	½ x 1½	0.95	
420	1½"	SAFT 624	63.5	50.8	0/32	79.38	113	36.50	95.0	32	12.7	17.0	M 16 x 55	⅜ x 2	1.61	
420	2"	SAFT 632	79.4	66.5	0/40	96.82	133	44.45	113.8	40	12.7	21.0	M 20 x 65	⅜ x 2½	2.51	

# SAE J 518 C 61/62 Flanges

SAE - locking sheet

**SAAP**

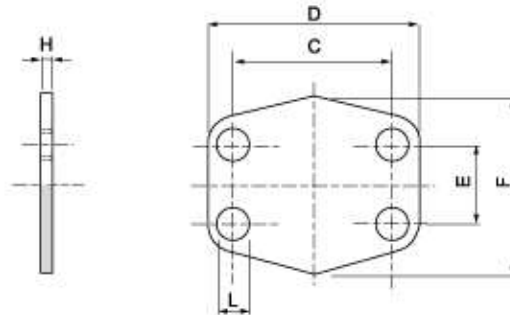

Maximum recommended working pressure kg/cm <sup>2</sup>	Nominal flange size, in	Type	Dimensions						Weight kg
			C	D	E	F	H	L	
		<b>Standard Pressure</b>							
-	½"	SAAP 308	38.10	54	17.48	45.6	3	9.0	0.01
-	¾"	SAAP 312	47.63	65	22.23	51.8	3	11.0	0.01
-	1"	SAAP 316	52.37	70	26.19	58.4	3	11.0	0.01
-	1¼"	SAAP 320	58.72	79	30.18	72.6	3	11.5	0.02
-	1½"	SAAP 324	69.85	94	35.71	82.2	3	13.5	0.02
-	2"	SAAP 332	77.77	102	42.88	90.0	3	13.5	0.03
-	2½"	SAAP 340	88.90	114	50.80	108.12	3	13.5	0.03
-	3"	SAAP 348	106.38	134	61.93	130.6	4	17.0	0.04
-	3½"	SAAP 356	120.65	152	69.85	139.0	4	17.0	0.06
-	4"	SAAP 364	130.18	162	77.77	152.0	4	17.0	0.08
-	5"	SAAP 380	152.40	184	92.08	180.0	4	17.0	0.09
		<b>High Pressure</b>							
-	½"	SAAP 608	40.49	56	18.24	47.2	4	9.0	0.01
-	¾"	SAAP 612	50.80	71	23.80	60.0	4	11.0	0.01
-	1"	SAAP 616	57.15	81	27.76	69.6	4	12.5	0.02
-	1¼"	SAAP 620	66.68	95	31.75	77.2	4	14.5	0.03
-	1½"	SAAP 624	79.38	113	36.50	95.0	4	17.0	0.04
-	2"	SAAP 632	96.82	133	44.45	113.8	4	21.0	0.05

# SAE J 518 C 61/62 Flanges

SAE - adapter sheet

SAEP

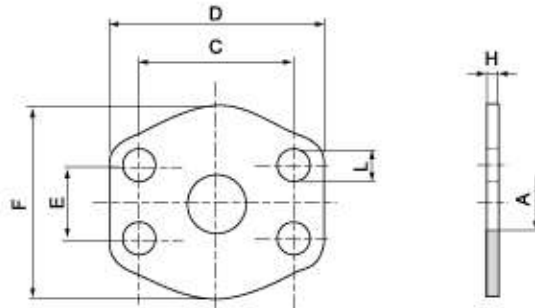

Maximum recommended working pressure kg/cm <sup>2</sup>	Nominal flange size, in	Type	Dimensions						Weight kg	
			A	C	D	E	F	H		L
		<b>Standard Pressure</b>								
-	½"	SAZP 308	13	38.10	54	17.48	45.6	3	9.0	0.01
-	¾"	SAZP 312	19	47.63	65	22.23	51.8	3	11.0	0.01
-	1"	SAZP 316	25	52.37	70	26.19	58.4	3	11.0	0.01
-	1½"	SAZP 320	32	58.72	79	30.18	72.6	3	11.5	0.02
-	1½"	SAZP 324	38	69.85	94	35.71	82.2	3	13.5	0.02
-	2"	SAZP 332	51	77.77	102	42.88	90.0	3	13.5	0.03
-	2½"	SAZP 340	63	88.90	114	50.80	108.0	3	13.5	0.03
-	3"	SAZP 348	73	106.38	134	61.93	130.6	4	17.0	0.04
-	3½"	SAZP 356	89	120.65	152	69.85	139.0	4	17.0	0.06
-	4"	SAZP 364	99	130.18	162	77.77	152.0	4	17.0	0.08
-	5"	SAZP 380	120	152.40	184	92.08	180.0	4	17.0	0.09
		<b>High Pressure</b>								
-	½"	SAZP 608	13	40.49	56	18.24	47.2	4	9.0	0.01
-	¾"	SAZP 612	17	50.80	71	23.80	60.0	4	11.0	0.01
-	1"	SAZP 616	24	57.15	81	27.76	69.6	4	12.5	0.02
-	1½"	SAZP 620	31	66.68	95	31.75	77.2	4	14.5	0.03
-	1½"	SAZP 624	38	79.38	113	36.50	95.0	4	17.0	0.04
-	2"	SAZP 632	51	96.82	133	44.45	113.8	4	21.0	0.05



# SAE J 518 C 61/62 Flanges

SAE - adapter flange with test point

**SAAGL**

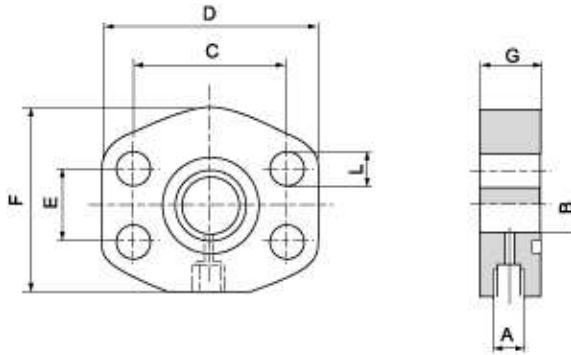

Maximum recommended working pressure kg/cm <sup>2</sup>	Nominal flange size, in	Type	Dimensions							Weight kg	
			A	B	C	D	E	F	G		L
		<b>Standard Pressure</b>									
350	½"	SAAGL 308	G ¼"	12	38.10	55	17.48	38	24	9.0	0.45
350	¾"	SAAGL 312	G ½"	19	47.63	65	22.23	50	24	11.0	0.60
350	1"	SAAGL 316	G ¾"	24	52.37	70	26.19	50	24	11.0	0.60
280	1 ¼"	SAAGL 320	G 1"	32	58.72	81	30.18	70	23	11.5	0.75
210	1 ½"	SAAGL 324	G 1 ¼"	38	69.85	95	35.71	78	24	13.5	0.80
210	2"	SAAGL 332	G 1 ½"	50	77.77	102	42.88	90	24	13.5	1.25
		<b>High Pressure</b>									
420	½"	SAAGL 608	G ¼"	12	40.49	55	18.24	38	24	9.0	0.45
420	¾"	SAAGL 612	G ½"	19	50.80	70	23.80	50	24	11.0	0.60
420	1"	SAAGL 616	G ¾"	24	57.15	81	27.76	70	23	12.5	0.75
420	1 ¼"	SAAGL 620	G 1"	32	66.68	95	31.75	78	24	14.5	0.80
420	1 ½"	SAAGL 624	G 1 ¼"	38	79.38	112	36.50	94	24	17.0	1.40
420	2"	SAAGL 632	G 1 ½"	51	96.82	134	44.45	114	24	21.0	1.57

# SAE J 518 C 61/62 Flanges

SAE - adapter 90° - welded

**SAAG**

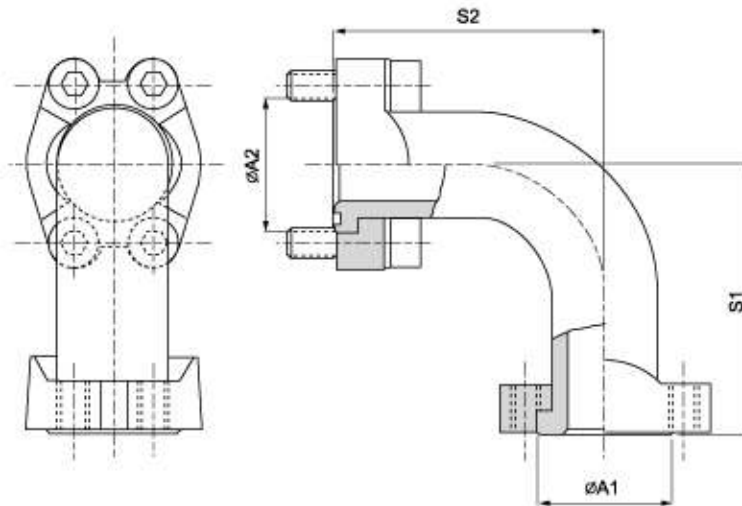

Maximum recommended working pressure kg/cm <sup>2</sup>	Nominal flange size, in	Type	Dimensions				Weight kg
			A1	A2	S1	S2	
		<b>Standard Pressure</b>					
350	½"	SAAG 308	30.2	30.2	70	70	0.65
350	¾"	SAAG 312	38.1	38.1	80	80	0.90
350	1"	SAAG 316	44.4	44.4	90	90	1.15
210	1 ½"	SAAG 320	50.8	50.8	103	103	1.50
210	1 ½"	SAAG 324	60.3	60.3	115	115	2.55
210	2"	SAAG 332	71.4	71.4	135	135	2.79
175	2 ½"	SAAG 340	84.1	84.1	155	155	3.20
35	3"	SAAG 348	101.6	101.6	175	175	4.60
35	3 ½"	SAAG 356	114.3	114.3	175	175	5.12
35	4"	SAAG 364	127.0	127.0	215	215	6.25
35	5"	SAAG 380	152.4	152.4	250	250	7.65

# SAE J 518 C 61/62 Flanges

SAE - T- connection - welded

**SAT**

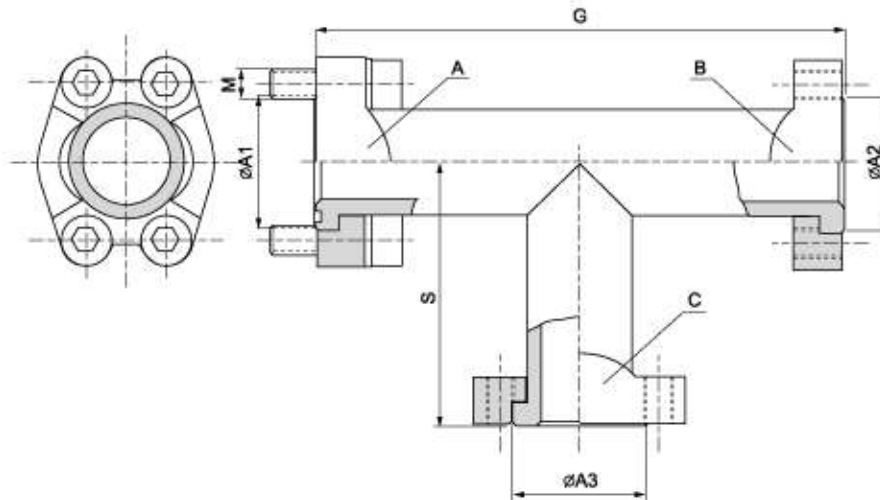

Maximum recommended working pressure kg/cm <sup>2</sup>	Type	Connection A			Connection B		Connection C		G	S	Weight kg
		Size	A1	M	Size	A2	Size	A3			
350	SAT 308	½"	30.2	M 8 x 30	½"	30.2	½"	30.2	133	67	0.97
350	SAT 312	¾"	38.1	M 10 x 35	¾"	38.1	¾"	38.1	160	80	1.20
350	SAT 316	1"	44.4	M 10 x 35	1"	44.4	1"	44.4	177	88	1.63
210	SAT 320	1¼"	50.8	M 10 x 30	1¼"	50.8	1¼"	50.8	208	103	2.25
210	SAT 324	1½"	60.3	M 12 x 35	1½"	60.3	1½"	60.3	230	114	3.50
210	SAT 332	2"	71.4	M 12 x 35	2"	71.4	2"	71.4	244	122	4.20
175	SAT 340	2½"	84.1	M 12 x 40	2½"	84.1	2½"	84.1	270	135	4.70
140	SAT 348	3"	101.6	M 16 x 50	3"	101.6	3"	101.6	293	146	8.20
35	SAT 356	3½"	114.3	M 16 x 50	3½"	114.3	3½"	114.3	293	146	9.55
35	SAT 364	4"	127.0	M 16 x 50	4"	127.0	4"	127.0	332	165	12.10
35	SAT 380	5"	152.4	M 16 x 50	5"	152.4	5"	152.4	370	185	14.70



# SAE J 518 C 61/62 Flanges

SAE - 90° L - Block

**SAL - GD**

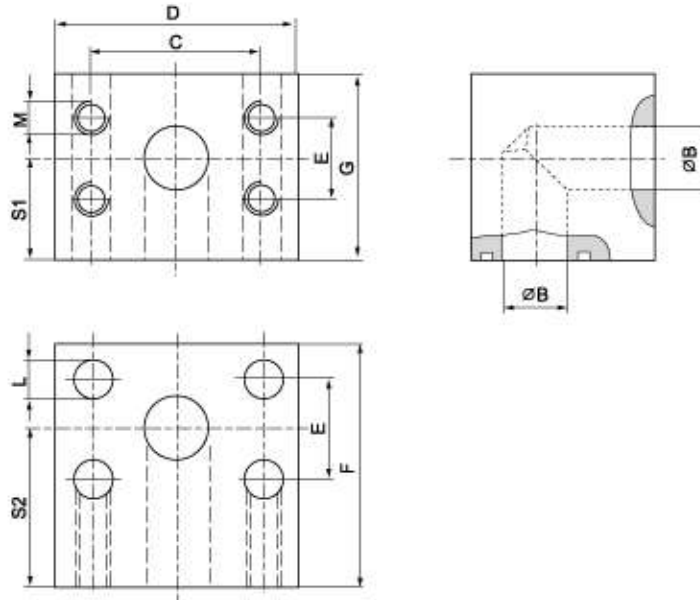

Maximum recommended working pressure kg/cm <sup>2</sup>	Nominal flange size, in	Type	Dimensions										Weight kg	
			B	C	D	E	F	G	L	M	S1	S2		
		<b>Standard Pressure</b>												
350	½"	SAL-GD 308	13	38.10	55	17.48	55	50	9.0	M 8	25.0	35	1.0	
350	¾"	SAL-GD 312	19	47.65	65	23.25	60	60	11.0	M 10	30.0	40	1.2	
350	1"	SAL-GD 316	24	52.40	72	26.20	65	65	11.0	M 10	33.0	40	1.9	
280	1 ¼"	SAL-GD 320	32	58.72	82	30.18	82	80	11.5	M 10	39.0	38	3.5	
210	1 ½"	SAL-GD 324	38	69.85	98	35.71	92	92	13.5	M 12	51.0	59	5.0	
210	2"	SAL-GD 332	46	77.77	102	42.88	85	87	13.5	M 12	51.0	48	7.9	
175	2 ½"	SAL-GD 340	62	88.90	115	50.80	110	120	13.5	M 12	60.0	65	8.6	
140	3"	SAL-GD 348	73	106.38	135	61.93	150	135	17.0	M 16	67.5	90	10.5	
		<b>High Pressure</b>												
420	½"	SAL-GD 608	13	40.50	60	18.25	60	50	9.0	M 8	25.0	40	1.0	
420	¾"	SAL-GD 612	19	50.80	72	23.80	60	55	11.0	M 10	32.0	36	1.4	
420	1"	SAL-GD 616	23	57.15	82	27.76	68	64	13.0	M 12	37.0	40	2.3	
420	1 ¼"	SAL-GD 620	30	66.68	96	31.75	76	72	15.0	M 14	41.0	46	3.3	
420	1 ½"	SAL-GD 624	38	79.38	114	36.50	86	89	17.0	M 16	50.0	52	5.4	
420	2"	SAL-GD 632	50	96.82	133	44.45	110	105	21.0	M 20	59.0	70	9.0	
420	2 ½"	SAL-GD 640	62	123.80	180	58.80	160	155	26.0	M 24	77.5	90	14.6	

# SAE J 518 C 61/62 Flanges

SAE - 90° L - Block - companion

**SAL - BL**

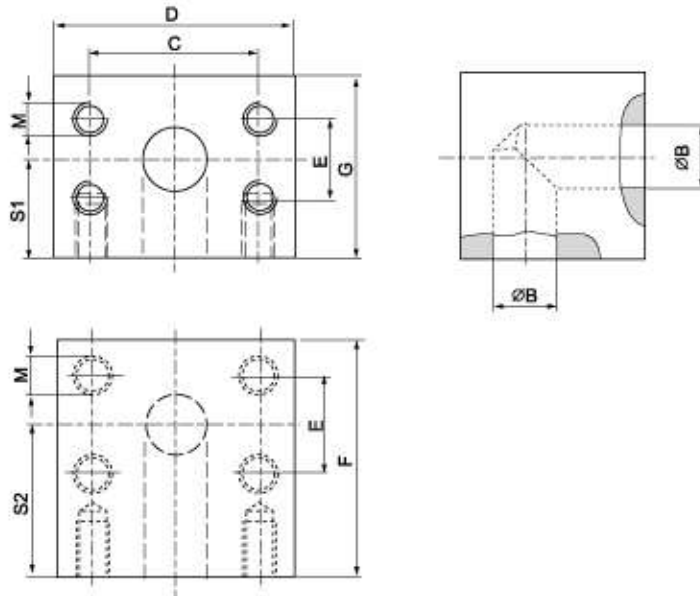

Maximum recommended working pressure kg/cm <sup>2</sup>	Nominal flange size, in	Type	Dimensions								Weight kg	
			B	C	D	E	F	G	M	S1		S2
		<b>Standard Pressure</b>										
350	½"	SAL-BL 308	13	38.10	55	17.48	55	50	M 8	25.0	35	1.0
350	¾"	SAL-BL 312	19	47.65	65	23.25	60	60	M 10	30.0	40	1.2
350	1"	SAL-BL 316	24	52.40	72	26.20	65	65	M 10	33.0	40	1.9
280	1½"	SAL-BL 320	32	58.72	82	30.18	82	80	M 10	39.0	38	3.5
210	1½"	SAL-BL 324	38	69.85	98	35.71	92	92	M 12	51.0	59	5.0
210	2"	SAL-BL 332	46	77.77	102	42.88	85	87	M 12	51.0	48	7.9
175	2½"	SAL-BL 340	62	88.90	110	50.80	110	120	M 12	60.0	65	8.6
140	3"	SAL-BL 348	73	106.38	135	61.93	150	135	M 16	67.5	90	10.5
		<b>High Pressure</b>										
420	½"	SAL-BL 608	13	40.50	60	18.25	60	50	M 8	2.8	40	1.0
420	¾"	SAL-BL 612	19	50.80	72	23.80	60	55	M 10	32.0	36	1.4
420	1"	SAL-BL 616	23	57.15	82	27.76	68	64	M 12	37.0	40	2.3
420	1½"	SAL-BL 620	30	66.68	96	31.75	72	72	M 14	41.0	46	3.3
420	1½"	SAL-BL 624	38	79.38	114	36.50	86	89	M 16	50.0	52	5.3
420	2"	SAL-BL 632	50	96.82	133	44.45	110	105	M 20	59.0	70	9.0
420	2½"	SAL-BL 640	62	123.80	180	58.80	160	155	M 24	77.5	90	14.6

# SAE J 518 C 61/62 Flanges

SAE - 90° L - reduction

## SARED - GD

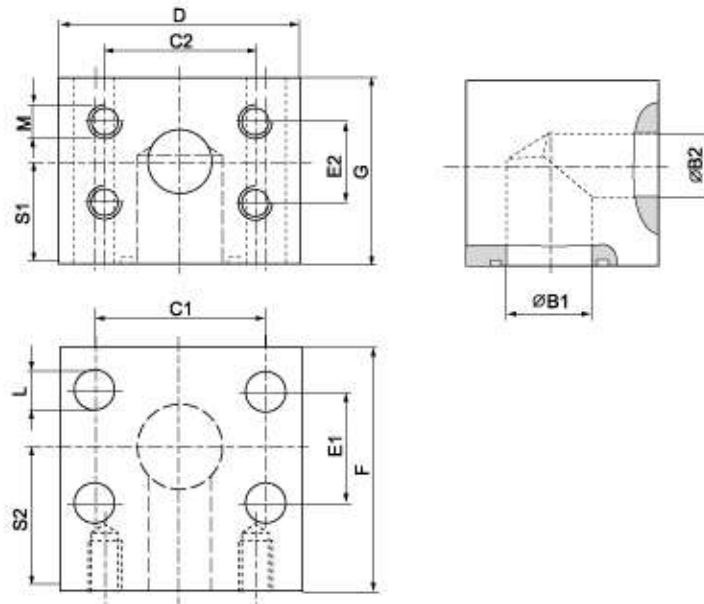

Maximum recommended working pressure kg/cm <sup>2</sup>	Nominal flange size, in	Type	Dimensions												Weight kg		
			B1	B2	C1	C2	D	E1	E2	F	G	L	M	S1		S2	
		<b>High Pressure</b>															
420	1"	SARED-GD 616-08	23	19	57.15	50.80	82	27.76	23.80	68	64	13	M 10	37	40	2.8	
420	1 ¼"	SARED-GD 620-08	30	19	66.68	50.80	96	31.75	23.80	72	72	15	M 10	41	46	3.6	
420	1 ½"	SARED-GD 620-12	30	23	66.68	57.15	96	31.75	27.76	76	72	15	M 12	41	46	3.3	
420	1 ¾"	SARED-GD 624-20	38	30	79.38	66.68	114	36.50	31.75	86	89	17	M 14	50	52	5.7	
420	2"	SARED-GD 632-24	50	38	96.82	79.38	133	44.45	36.50	110	105	21	M 16	63	70	9.0	



# SAE J 518 C 61/62 Flanges

SAE - T - block

**SAT - GD**

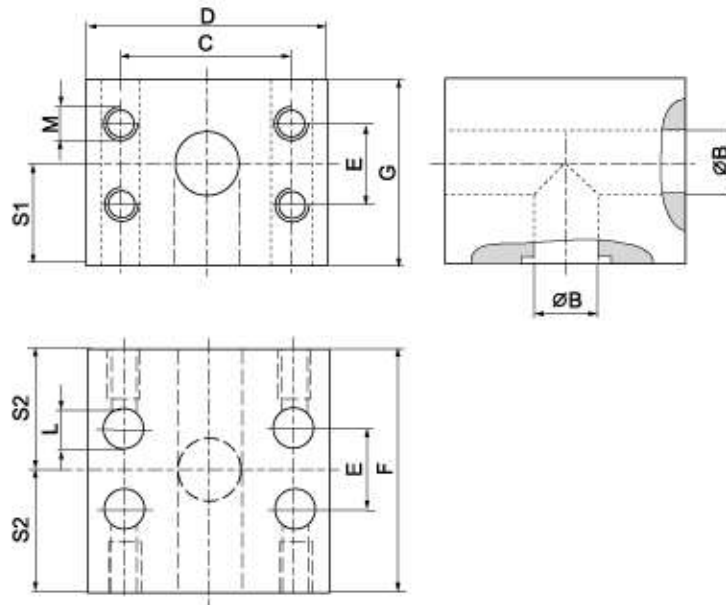

Maximum recommended working pressure kg/cm <sup>2</sup>	Nominal flange size, in	Type	Dimensions										Weight kg
			B	C	D	E	F	G	L	M	S1	S2	
		<b>High Pressure</b>											
420	¾"	SAT-GD 612	19	50.80	72	23.80	72	55	11	M 10	32	36	1.7
420	1"	SAT-GD 616	23	57.15	82	27.76	80	64	13	M 12	37	40	2.9
420	1¼"	SAT-GD 620	30	66.68	96	31.75	92	72	15	M 14	41	46	3.8
420	1½"	SAT-GD 624	38	79.38	114	36.50	104	89	17	M 16	50	52	8.9
420	2"	SAT-GD 632	50	96.82	133	44.45	140	105	21	M 20	63	70	12.7

# SAE J 518 C 61/62 Flanges

SAE - T - block - companion flange

**SAT - BL**

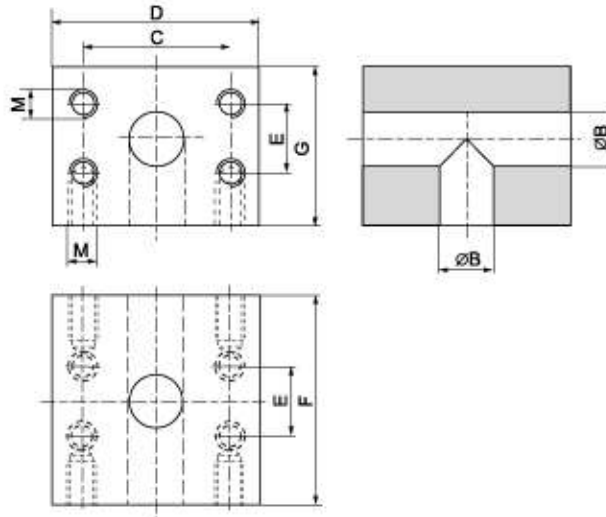

Maximum recommended working pressure kg/cm <sup>2</sup>	Nominal flange size, in	Type	Dimensions							Weight kg
			B	C	D	E	F	G	M	
<b>Standard Pressure</b>										
350	1/2"	SAT-BL-308	13	38.10	55	17.48	70	50	M 8	1.4
350	3/8"	SAT-BL-312	19	47.63	65	22.23	75	55	M 10	1.8
350	1"	SAT-BL-316	25	52.37	70	26.19	80	60	M 10	2.3
280	1 1/2"	SAT-BL-320	32	58.72	80	30.18	90	70	M 10	3.9
210	1 1/2"	SAT-BL-324	38	69.85	95	35.71	110	85	M 12	6.3
210	2"	SAT-BL-332	50	77.77	100	42.88	120	110	M 12	8.3
175	2 1/2"	SAT-BL-340	63	88.90	120	50.80	160	120	M 12	11.6
140	3"	SAT-BL-348	73	106.38	135	61.93	160	160	M 16	15.3
<b>High Pressure</b>										
420	1/2"	SAT-BL-608	12	40.49	60	18.24	90	50	M 8	1.3
420	3/8"	SAT-BL-612	19	50.80	72	23.80	72	55	M 10	1.7
420	1"	SAT-BL-616	23	57.15	82	27.76	80	64	M 12	2.9
420	1 1/2"	SAT-BL-620	30	66.68	100	31.75	92	72	M 14	3.8
420	1 1/2"	SAT-BL-624	38	79.38	110	36.50	100	100	M 16	8.9
420	2"	SAT-BL-632	50	96.82	133	44.45	140	105	M 20	12.7
420	2 1/2"	SAT-BL-640	62	123.80	180	58.80	180	155	M 24	16.5

# ISO 6164 Flanges

Butt weld centering flange-ND 160-ISO 6164-1

## SAVKA / VKK 16

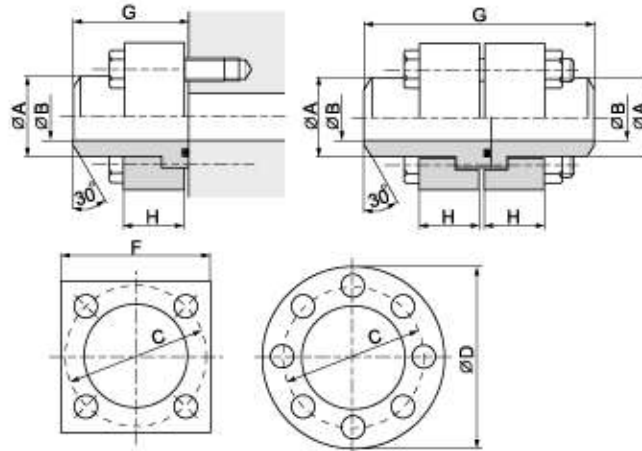

Maximum recommended working pressure kg/cm <sup>2</sup>	DN	Type	Dimensions							Screws	O-Ring	Weight kg	
			A	B	C	F	D	H	G				
		<b>Weld-on flange</b>											
160	3/8"	SAVKA1606	17.1 x 2.3	13	44	50			20	43	4 x M10 x 35	16.3 x 2.4	0.40
160	1/2"	SAVKA1608	21.3 x 2.7	16	54	50			20	50	4 x M10 x 35	25.3 x 2.4	0.70
160	3/4"	SAVKA1612	26.7 x 2.9	21	54	60			20	50	4 x M10 x 35	25.3 x 2.4	0.70
160	1"	SAVKA1616	33.4 x 3.4	27	64	70			20	56	4 x M12 x 35	29.8 x 2.6	0.90
160	1 1/4"	SAVKA1620	42.2 x 3.6	35	72	80			24	64	4 x M12 x 40	34.5 x 2.6	1.40
160	1 1/2"	SAVKA1624	48.3 x 3.7	41	80	90			29	68	4 x M16 x 50	43.0 x 3.0	2.20
160	2"	SAVKA1626	60.3 x 3.9	53	98	100			40	80	4 x M16 x 60	53.3 x 5.33	3.20
160	2 1/2"	SAVKA1640	73.0 x 3.9	65	118	120			50	98	4 x M20 x 70	61.0 x 5.0	5.60
160	3"	SAVKA1648	88.9 x 5.2	79	145	150			54	109	4 x M24 x 75	75.0 x 5.0	9.50
160	3 1/2"	SAVKA1656	101.5 x 5.5	91	175	180			58	135	4 x M30 x 90	88.0 x 6.0	17.60
160	4"	SAVKA1664	114.3 x 5.7	103	175	180			58	135	4 x M30 x 90	88.0 x 6.0	17.60
160	5"	SAVKA1680	141.3 x 6.6	128	200			245	70	150	8 x M24 x 100	115.0 x 6.0	29.30
160	6"	SAVKA1696	168.3 x 7.1	154	245			300	80	190	8 x M30 x 110	148.0 x 7.0	48.20
160	8"	SAVKA16128	219.1 x 8.2	203	290			355	90	190	8 x M36 x 130	183.5 x 7.0	55.10
		<b>Weld-on flange coupling</b>											
160	3/8"	SAVKK1606	17.1 x 2.3	13	44	50			20	87	4 x M10 x 55	16.3 x 2.4	0.80
160	1/2"	SAVKK1608	21.3 x 2.7	16	54	50			20	101	4 x M10 x 60	25.3 x 2.4	1.40
160	3/4"	SAVKK1612	26.7 x 2.9	21	54	60			20	101	4 x M12 x 60	29.8 x 2.6	1.40
160	1"	SAVKK1616	33.4 x 3.4	27	64	70			20	113	4 x M12 x 60	34.5 x 2.6	1.80
160	1 1/4"	SAVKK1620	42.2 x 3.6	35	72	80			24	129	4 x M16 x 70	43.0 x 3.0	2.80
160	1 1/2"	SAVKK1624	48.3 x 3.7	41	80	90			29	137	4 x M16 x 80	43.0 x 3.0	4.40
160	2"	SAVKK1626	60.3 x 3.9	53	98	100			40	161	4 x M16 x 100	53.3 x 5.33	6.40
160	2 1/2"	SAVKK1640	73.0 x 3.9	65	118	120			50	197	4 x M20 x 120	61.0 x 5.0	11.20
160	3"	SAVKK1648	88.9 x 5.2	79	145	150			54	219	4 x M24 x 130	75.0 x 5.0	19.00
160	3 1/2"	SAVKK1656	101.5 x 5.5	91	175	180			58	271	4 x M30 x 150	88.0 x 6.0	35.20
160	4"	SAVKK1664	114.3 x 5.7	103	175	180			58	271	4 x M30 x 150	88.0 x 6.0	35.20
160	5"	SAVKK1680	141.3 x 6.6	128	200			245	70	301	8 x M24 x 170	115.0 x 6.0	58.60
160	6"	SAVKK1696	168.3 x 7.1	154	245			300	80	380	8 x M30 x 200	148.0 x 7.0	96.40
160	8"	SAVKK16128	219.1 x 8.2	203	290			355	90	380	8 x M36 x 220	183.5 x 7.0	110.20



# ISO 6164 Flanges

Butt weld centering flange - PN 250 - ISO 6164 - 1

**SAVKA / VKK 25**

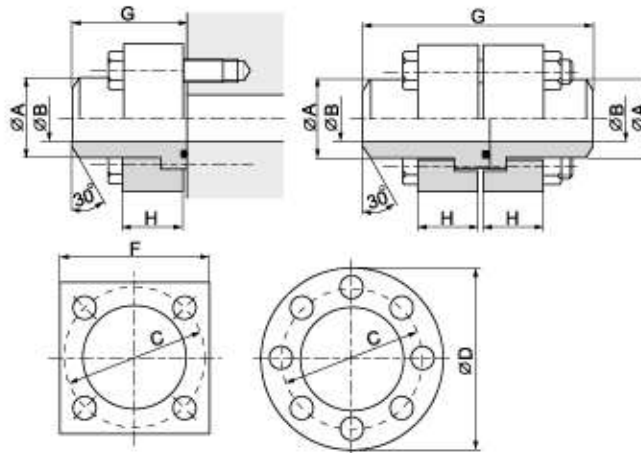

Maximum recommended working pressure kg/cm <sup>2</sup>	DN	Type	Dimensions							Screws	O-Ring	Weight kg	
			A	B	C	F	D	H	G				
		<b>Weld-on flange</b>											
250	3/8"	SAVKA2506	17.1 x 3.2	11	44	50			20	43	4 x M10 x 35	16.3 x 2.4	0.40
250	1/2"	SAVKA2508	21.3 x 3.7	14	54	60			20	50	4 x M10 x 35	25.3 x 2.4	0.70
250	3/4"	SAVKA2512	26.7 x 3.9	19	64	70			20	56	4 x M12 x 35	29.8 x 2.6	0.90
250	1"	SAVKA2516	33.4 x 5.4	24	72	80			25	64	4 x M12 x 40	34.5 x 2.6	1.45
250	1 1/4"	SAVKA2520	42.2 x 4.9	32	80	90			32	68	4 x M16 x 50	43.0 x 3.0	2.20
250	1 1/2"	SAVKA2524	48.3 x 5.1	38	85	90			34	68	4 x M16 x 50	43.0 x 3.0	2.20
250	2"	SAVKA2526	60.3 x 5.5	49	98	100			40	80	4 x M16 x 60	53.3 x 5.33	3.20
250	2 1/2"	SAVKA2540	73.0 x 7.0	59	118	120			50	98	4 x M20 x 70	61.0 x 5.0	5.60
250	3"	SAVKA2548	88.9 x 7.6	74	145	150			54	109	4 x M24 x 75	75.0 x 5.0	9.50
250	3 1/2"	SAVKA2556	101.5 x 8.1	85	175	180			58	135	4 x M30 x 90	88.0 x 6.0	17.60
250	4"	SAVKA2564	114.3 x 8.6	97	175	180			58	135	4 x M30 x 90	88.0 x 6.0	17.60
250	5"	SAVKA2580	141.3 x 9.5	122	200		245	70	150	8 x M24 x 100	115.0 x 6.0	29.30	
250	6"	SAVKA2596	168.3 x 11.0	146	245		300	80	190	8 x M30 x 110	148.0 x 7.0	48.20	
250	8"	SAVKA25128	219.1 x 12.7	194	290		355	90	190	8 x M36 x 130	183.5 x 7.0	55.10	
		<b>Weld-on flange coupling</b>											
250	3/8"	SAVKK2506	17.1 x 3.2	11	44	50			20	87	4 x M10 x 55	16.3 x 2.4	0.80
250	1/2"	SAVKK2508	21.3 x 3.7	14	54	60			20	101	4 x M10 x 60	25.3 x 2.4	1.40
250	3/4"	SAVKK2512	26.7 x 3.9	19	64	70			20	113	4 x M12 x 60	29.8 x 2.6	1.80
250	1"	SAVKK2516	33.4 x 5.4	24	72	80			25	129	4 x M12 x 70	34.5 x 2.6	2.90
250	1 1/4"	SAVKK2520	42.2 x 4.9	32	80	90			32	137	4 x M16 x 80	43.0 x 3.0	4.40
250	1 1/2"	SAVKK2524	48.3 x 5.1	38	80	90			34	137	4 x M16 x 80	43.0 x 3.0	4.40
250	2"	SAVKK2526	60.3 x 5.5	49	98	100			40	161	4 x M16 x 100	53.3 x 5.33	6.40
250	2 1/2"	SAVKK2540	73.0 x 7.0	59	118	120			50	197	4 x M20 x 120	61.0 x 5.0	11.20
250	3"	SAVKK2548	88.9 x 7.6	74	145	150			54	219	4 x M24 x 130	75.0 x 5.0	19.00
250	3 1/2"	SAVKK2556	101.5 x 8.1	85	175	180			58	271	4 x M30 x 150	88.0 x 6.0	35.20
250	4"	SAVKK2564	114.3 x 8.6	97	175	180			58	271	4 x M30 x 150	88.0 x 6.0	35.20
250	5"	SAVKK2580	141.3 x 9.5	122	200		245	70	301	8 x M24 x 170	115.0 x 6.0	58.60	
250	6"	SAVKK2596	168.3 x 11.0	146	245		300	80	380	8 x M30 x 200	148.0 x 7.0	96.40	
250	8"	SAVKK25128	219.1 x 12.7	194	290		355	90	380	8 x M36 x 220	183.5 x 7.0	110.20	

# ISO 6164 Flanges

Butt weld centering flange-ND 350-ISO 6164-2

**SAVKA / VKK 35**

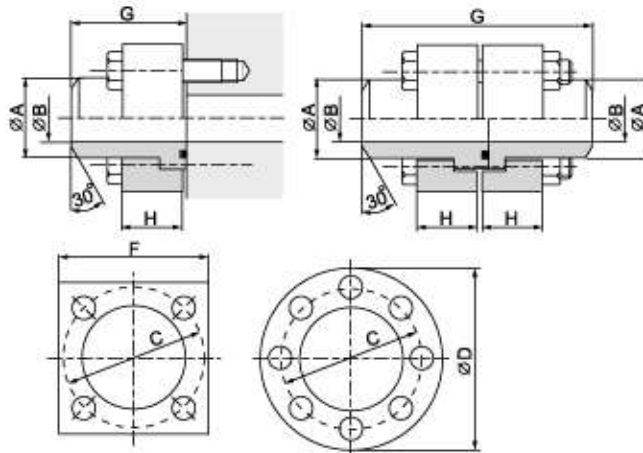

Maximum recommended working pressure kg/cm <sup>2</sup>	DN	Type	Dimensions							Screws	O-Ring	Weight kg
			A	B	C	F	D	H	G			
		<b>Weld-on flange</b>										
350	3/8"	SAVKA3506	17.1 x 3.6	10	44	50		20	43	4 x M10 x 35	16.3 x 2.4	0.40
350	1/2"	SAVKA3508	21.3 x 4.7	12	54	60		20	50	4 x M10 x 35	25.3 x 2.4	0.70
350	3/4"	SAVKA3512	26.7 x 5.5	16	54	60		20	50	4 x M10 x 35	25.3 x 2.4	0.70
350	1"	SAVKA3516	33.4 x 6.4	21	64	70		25	56	4 x M12 x 40	29.8 x 2.6	0.90
350	1 1/4"	SAVKA3520	42.2 x 6.4	29	72	80		32	64	4 x M12 x 50	34.5 x 2.6	1.45
350	1 1/2"	SAVKA3524	48.3 x 7.1	34	80	90		34	68	4 x M16 x 50	43.0 x 3.0	2.20
350	2"	SAVKA3526	60.3 x 8.7	43	98	100		40	80	4 x M16 x 60	53.3 x 5.33	3.20
350	2 1/2"	SAVKA3540	73.0 x 9.5	54	118	120		50	98	4 x M20 x 70	61.0 x 5.0	5.60
350	3"	SAVKA3548	88.9 x 11.1	67	145	150		54	109	4 x M24 x 75	75.0 x 5.0	9.50
350	3 1/2"	SAVKA3556	101.5 x 12.7	76	175	180		58	135	4 x M30 x 90	88.0 x 6.0	17.60
350	4"	SAVKA3564	114.3 x 13.5	87	175	180		58	135	4 x M30 x 90	88.0 x 6.0	17.60
350	5"	SAVKA3580	141.3 x 15.9	110	200		245	70	150	8 x M24 x 100	115.0 x 6.0	29.30
350	6"	SAVKA3596	168.3 x 18.3	132	245		300	80	190	8 x M30 x 110	148.0 x 7.0	48.20
350	8"	SAVKA35128	219.1 x 23.0	173	290		355	90	190	8 x M36 x 130	183.5 x 7.0	55.10
		<b>Weld-on flange coupling</b>										
350	3/8"	SAVKK3506	17.1 x 3.6	10	44	50		20	87	4 x M10 x 55	16.3 x 2.4	0.80
350	1/2"	SAVKK3508	21.3 x 4.7	12	54	60		20	101	4 x M10 x 60	25.3 x 2.4	1.40
350	3/4"	SAVKK3512	26.7 x 5.5	16	54	60		20	101	4 x M10 x 60	25.3 x 2.4	1.40
350	1"	SAVKK3516	33.4 x 6.4	21	64	70		25	113	4 x M12 x 70	29.8 x 2.6	1.80
350	1 1/4"	SAVKK3520	42.2 x 6.4	29	72	80		32	129	4 x M16 x 80	34.5 x 2.6	2.90
350	1 1/2"	SAVKK3524	48.3 x 7.1	34	80	90		34	137	4 x M16 x 80	43.0 x 3.0	4.40
350	2"	SAVKK3526	60.3 x 8.7	43	98	100		40	161	4 x M16 x 100	53.3 x 5.33	6.40
350	2 1/2"	SAVKK3540	73.0 x 9.5	54	118	120		50	197	4 x M20 x 120	61.0 x 5.0	11.20
350	3"	SAVKK3548	88.9 x 11.1	67	145	150		54	219	4 x M24 x 130	75.0 x 5.0	19.00
350	3 1/2"	SAVKK3556	101.5 x 12.7	76	175	180		58	271	4 x M30 x 150	88.0 x 6.0	35.20
350	4"	SAVKK3564	114.3 x 13.5	87	175	180		58	271	4 x M30 x 150	88.0 x 6.0	35.20
350	5"	SAVKK3580	141.3 x 15.9	110	200		245	70	301	8 x M24 x 170	115.0 x 6.0	58.60
350	6"	SAVKK3596	168.3 x 18.3	132	245		300	80	380	8 x M30 x 200	148.0 x 7.0	96.40
350	8"	SAVKK35128	219.1 x 23.0	173	290		355	90	380	8 x M36 x 220	183.5 x 7.0	110.20



# ISO 6164 Flanges

Butt weld centering flange - PN 400 - ISO 6164 - 2

## SAVKA / VKK 40

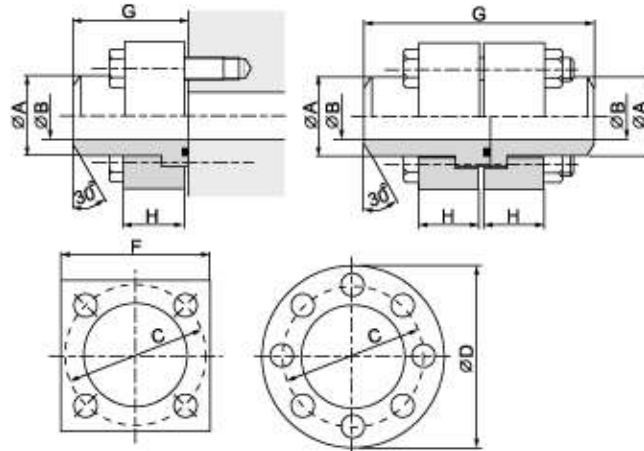

Maximum recommended working pressure kg/cm <sup>2</sup>	DN	Type	Dimensions							Screws	O-Ring	Weight kg	
			A	B	C	F	D	H	G				
		<b>Weld-on flange</b>											
400	½"	SAVKA4008	21.3 x 7.5	6	42	45			20	50	4 x M 8 x 35	20.0 x 2.65	0.70
400	¾"	SAVKA4012	26.7 x 7.8	11	54	60			20	50	4 x M10 x 35	23.6 x 3.55	0.90
400	1"	SAVKA4016	33.4 x 9.1	15	62	65			25	56	4 x M10 x 40	25.0 x 3.55	1.45
400	1¼"	SAVKA4020	42.2 x 9.7	23	73	75			32	64	4 x M12 x 50	31.5 x 3.55	2.20
400	1½"	SAVKA4024	48.3 x 10.2	28	85	90			34	68	4 x M14 x 50	37.5 x 3.55	2.20
400	2"	SAVKA4026	60.3 x 11.1	38	98	100			40	80	4 x M16 x 60	43.7 x 5.30	3.20
400	2½"	SAVKA4040	73.0 x 14.0	45	118	120			50	98	4 x M20 x 70	56.0 x 5.30	5.60
400	3"	SAVKA4048	88.9 x 15.2	59	145	150			54	109	4 x M24 x 75	65.0 x 5.30	9.50
400	3½"	SAVKA4056	101.5 x 20.0	61	160	160			58	135	4 x M24 x 90	71.0 x 5.30	17.60
400	4"	SAVKA4064	114.3 x 17.1	80	175	180			65	135	4 x M30 x 95	90.0 x 5.30	17.60
400	5"	SAVKA4080	141.3 x 19.0	103	200			245	70	150	8 x M24 x 100	115.0 x 6.0	29.30
400	6"	SAVKA4096	168.3 x 22.0	124	245			300	80	190	8 x M30 x 110	148.0 x 7.0	48.20
400	8"	SAVKA40128	219.1 x 22.2	175	290			355	90	190	8 x M36 x 130	183.5 x 7.0	55.10
		<b>Weld-on flange coupling</b>											
400	½"	SAVKK4008	21.3 x 7.5	6	42	45			20	101	4 x M 8 x 60	20.0 x 2.65	1.40
400	¾"	SAVKK4012	26.7 x 7.8	11	54	60			20	101	4 x M10 x 60	23.6 x 3.55	1.80
400	1"	SAVKK4016	33.4 x 9.1	15	62	65			25	113	4 x M10 x 60	25.0 x 3.55	2.90
400	1¼"	SAVKK4020	42.2 x 9.7	23	73	75			32	129	4 x M12 x 80	31.5 x 3.55	4.40
400	1½"	SAVKK4024	48.3 x 10.2	28	85	90			34	137	4 x M14 x 85	37.5 x 3.55	4.40
400	2"	SAVKK4026	60.3 x 11.1	38	98	100			40	161	4 x M16 x 100	43.7 x 5.30	6.40
400	2½"	SAVKK4040	73.0 x 14.0	45	118	120			50	197	4 x M20 x 130	56.0 x 5.30	11.20
400	3"	SAVKK4048	88.9 x 15.2	59	145	150			54	219	4 x M24 x 150	65.0 x 5.30	19.00
400	3½"	SAVKA4056	101.5 x 20.0	61	160	160			58	271	4 x M24 x 150	71.0 x 5.30	35.20
400	4"	SAVKK4064	114.3 x 17.1	80	175	180			65	271	4 x M30 x 160	90.0 x 5.30	35.20
400	5"	SAVKK4080	141.3 x 19.0	103	200			245	70	301	8 x M24 x 170	115.0 x 6.0	58.60
400	6"	SAVKK4096	168.3 x 22.0	124	245			300	80	380	8 x M30 x 200	148.0 x 7.0	96.40
400	8"	SAVKK40128	219.1 x 22.2	175	290			355	90	380	8 x M36 x 220	183.5 x 7.0	110.20



# ISO 6164 Flanges

T - connection

**SAVKV**

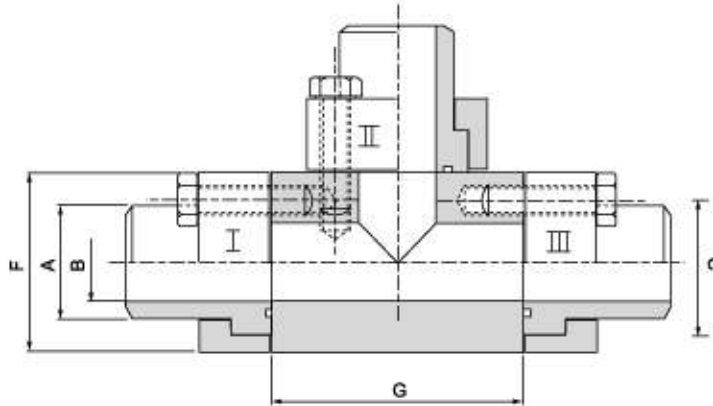

Maximum recommended working pressure kg/cm <sup>2</sup>	DN	Type	Dimensions					Screws	O-Ring	Weight flange only kg
			A	B	C	F	G			
		<b>Nominal pressure 250bar</b>								
250	3/8"	SAVKV 2506	17.1 x 3.2	11	44	50	100	4 x M10 x 35	16.3 x 2.40	
250	1/2"	SAVKV 2508	21.3 x 3.7	14	54	60	110	4 x M10 x 35	25.3 x 2.40	
250	3/4"	SAVKV 2512	26.7 x 3.9	19	64	70	115	4 x M12 x 35	29.8 x 2.60	
250	1"	SAVKV 2516	33.4 x 5.4	24	72	80	125	4 x M12 x 40	34.5 x 2.60	
250	1 1/4"	SAVKV 2520	42.2 x 4.9	32	80	90	140	4 x M16 x 50	43.0 x 3.00	
250	1 1/2"	SAVKV 2524	48.3 x 5.1	38	80	90	140	4 x M16 x 50	43.0 x 3.00	
250	2"	SAVKV 2526	60.3 x 5.5	49	98	100	160	4 x M16 x 60	53.3 x 5.33	
250	2 1/2"	SAVKV 2540	73.0 x 7.0	59	118	120	180	4 x M20 x 70	61.0 x 5.00	
250	3"	SAVKV 2548	88.9 x 7.6	74	145	150	200	4 x M24 x 75	75.0 x 5.00	
250	3 1/2"	SAVKV 2556	101.5 x 8.1	85	175	180	240	4 x M30 x 90	88.0 x 6.00	
		<b>Nominal pressure 400bar</b>								
400	3/8"	SAVKV 4008	21.3 x 7.5	6	54	60	110	4 x M10 x 35	25.3 x 2.40	
400	1/2"	SAVKV 4012	26.7 x 7.8	11	54	60	110	4 x M10 x 35	25.3 x 2.40	
400	1"	SAVKV 4016	33.4 x 9.1	15	64	70	115	4 x M12 x 35	29.8 x 2.60	
400	1 1/4"	SAVKV 4020	42.2 x 9.7	23	72	80	125	4 x M12 x 40	34.5 x 2.60	
400	1 1/2"	SAVKV 4024	48.3 x 10.2	28	80	90	140	4 x M16 x 50	43.0 x 3.00	
400	2"	SAVKV 4026	60.3 x 11.1	38	98	100	160	4 x M16 x 60	53.3 x 5.33	
400	2 1/2"	SAVKV 4040	73.0 x 14.0	45	118	120	180	4 x M20 x 70	61.0 x 5.00	
400	3"	SAVKV 4048	88.9 x 15.2	59	145	150	200	4 x M24 x 75	75.0 x 5.00	
400	4"	SAVKV 4064	114.3 x 17.1	80	175	180	240	4 x M30 x 90	88.0 x 6.00	

# ISO 6164 Flanges

Cetop - square flange

**SACET**

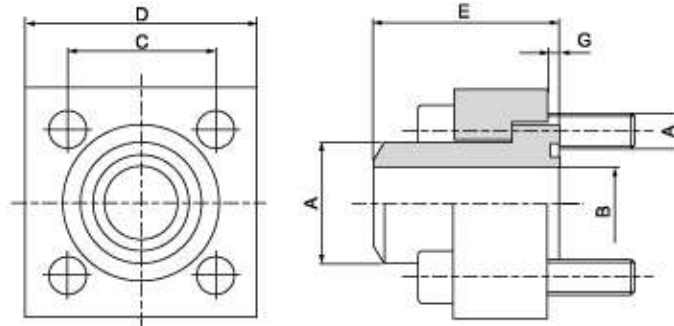

Maximum recommended working pressure kg/cm <sup>2</sup>	Nominal flange size, in	Type	Dimensions						Screws M	Weight kg
			A	B	C	D	E	G		
<b>Nominal pressure 250bar</b>										
250	3/8"	SACET 2506	17.5	12.5	24.7	40	30	1.0	M 6 x 25	0.17
250	1/2"	SACET 2508	21.6	15	29.7	45	30	1.0	M 8 x 30	0.22
250	3/4"	SACET 2512	27.2	20	35.3	50	35	1.0	M 8 x 30	0.32
250	1"	SACET 2516	34.0	25	43.8	65	40	1.0	M 10 x 35	0.63
250	1 1/2"	SACET 2520	42.8	32	51.6	75	45	1.0	M 12 x 40	0.92
250	1 1/2"	SACET 2524	48.6	38	60.0	85	50	1.0	M 14 x 45	1.34
250	2"	SACET 2532	61.0	47	69.4	100	60	1.5	M 16 x 55	2.30
250	2 1/2"	SACET 2540	73.5	58	83.4	120	70	1.5	M 20 x 65	4.00
250	3"	SACET 2548	90.5	70	102.5	140	80	1.5	M 20 x 75	6.03
250	3 1/2"	SACET 2556	103.0	80	102.5	140	90	1.5	M 20 x 90	7.56
250	4"	SACET 2564	115.0	90	113.2	160	105	1.5	M 24 x 100	10.96
<b>Nominal pressure 400bar</b>										
400	3/8"	SACET 4006	17.5	11	24.7	40	35	1.0	M 6 x 25	0.20
400	1/2"	SACET 4008	21.6	14	29.7	45	40	1.0	M 8 x 30	0.31
400	3/4"	SACET 4012	27.2	18	35.3	50	45	1.0	M 8 x 35	0.45
400	1"	SACET 4016	34.0	22	43.8	65	50	1.0	M 10 x 40	0.83
400	1 1/2"	SACET 4020	42.8	29	51.6	75	55	1.0	M 12 x 45	1.19
400	1 1/2"	SACET 4024	48.6	35	60.0	85	60	1.0	M 14 x 55	1.80
400	2"	SACET 4032	61.0	43	69.4	100	70	1.5	M 16 x 65	3.08
400	2 1/2"	SACET 4040	73.5	53	83.4	120	80	1.5	M 20 x 75	5.14
400	3"	SACET 4048	90.5	58	102.5	140	90	1.5	M 24 x 90	7.34
400	3 1/2"	SACET 4056	103.0	63	102.5	140	95	1.5	M 24 x 90	8.09
400	4"	SACET 4064	115.0	74	113.2	160	105	1.5	M 24 x 100	12.75

# ISO 6164 Flanges

Cetop - square flange connection

**SADCET**

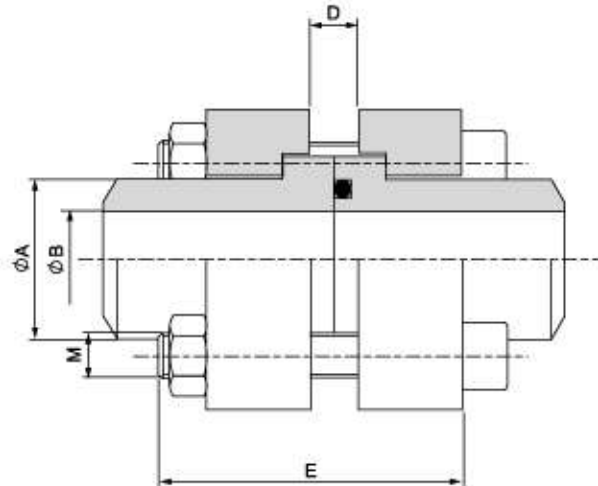
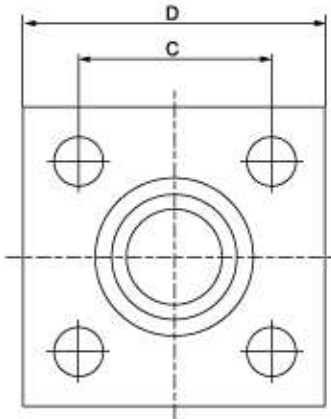

Maximum recommended working pressure kg/cm <sup>2</sup>	Nominal flange size, in	Type	Dimensions						Screws M	Weight kg
			A	B	C	D	E	G		
<b>Nominal pressure 250bar</b>										
250	3/8"	SADCET 2506	17.5	12.5	24.7	40	60	2.0	M 6 x 45	0.42
250	1/2"	SADCET 2508	21.6	15	29.7	45	60	2.0	M 8 x 50	0.52
250	3/4"	SADCET 2512	27.2	20	35.3	50	70	2.0	M 8 x 55	0.68
250	1"	SADCET 2516	34.0	25	43.8	65	80	2.0	M 10 x 65	1.30
250	1 1/4"	SADCET 2520	42.8	32	51.6	75	90	2.0	M 12 x 75	1.98
250	1 1/2"	SADCET 2524	48.6	38	60.0	85	100	2.0	M 14 x 90	2.79
250	2"	SADCET 2532	61.0	47	69.4	100	120	3.0	M 16 x 100	4.67
250	2 1/2"	SADCET 2540	73.5	58	83.4	120	140	3.0	M 20 x 110	7.96
250	3"	SADCET 2548	90.5	70	102.5	140	160	3.0	M 20 x 120	11.80
250	3 1/2"	SADCET 2556	103.0	80	102.5	140	180	3.0	M 20 x 130	14.10
250	4"	SADCET	115.0	90	114.5	160	210	3.0	M 24 x 170	21.60
<b>High Pressure</b>										
400	3/8"	SADCET 38 ST400	17.5	11	24.7	40	70	2.0	M 6 x 45	0.47
400	1/2"	SADCET 12 ST400	21.6	14	29.7	45	80	2.0	M 8 x 50	0.63
400	3/4"	SADCET 34 ST400	27.2	18	35.2	50	90	2.0	M 8 x 55	0.90
400	1"	SADCET 1 ST400	34.0	22	43.8	65	100	2.0	M 10 x 65	1.73
400	1 1/4"	SADCET114ST400	42.8	29	51.6	75	110	2.0	M 12 x 75	2.62
400	1 1/2"	SADCET112ST400	48.6	35	60.0	85	120	2.0	M 14 x 90	3.76
400	2"	SADCET 2 ST400	61.0	43	69.4	100	140	3.0	M 16 x 100	6.40
400	2 1/2"	SADCET212ST400	73.5	53	83.4	120	160	3.0	M 20 x 130	10.50
400	3"	SADCET 3 ST400	90.5	58	102.5	160	180	3.0	M 24 x 130	16.40
400	3 1/2"	SADCET312ST400	103.0	63	113.1	160	190	3.0	M 24 x 150	16.70
400	4"	SADCET 4 ST400	115.0	74	123.7	180	210	3.0	M 24 x 170	25.00



# ISO 6164 Flanges

Cetop - flange plug

**SABS**

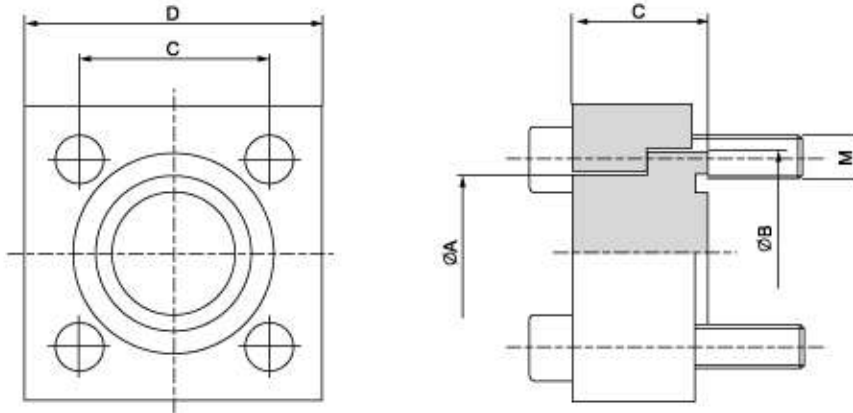

Maximum recommended working pressure kg/cm <sup>2</sup>	Nominal flange size, in	Type	Dimensions					Screws	Weight kg
			A	B	C	D	E		
<b>Nominal pressure 250bar</b>									
250	3/8"	SABS 2506	18	24.5	24.7	40	15	M 6 x 25	0.04
250	1/2"	SABS 2508	24	30.2	29.7	45	16	M 8 x 30	0.07
250	3/4"	SABS 2512	31.5	38.1	35.3	50	17	M 8 x 30	0.13
250	1"	SABS 2516	38	44.5	43.8	65	19	M 10 x 35	0.19
250	1 1/4"	SABS 2520	43	50.8	51.6	75	23	M 12 x 40	0.30
250	1 1/2"	SABS 2524	50	60.3	60.0	85	26	M 14 x 45	0.46
250	2"	SABS 2532	62	71.4	69.4	100	31	M 16 x 55	0.82
250	2 1/2"	SABS 2540	76	87.2	83.4	120	37	M 20 x 65	1.44
250	3"	SABS 2548	90	101.6	102.5	140	42	M 20 x 75	2.25
250	3 1/2"	SABS 2556	102	119.0	102.5	140	54	M 20 x 90	3.90
250	4"	SABS 2564	114	131.0	114.5	160	62	M 24 x 100	5.54
<b>Nominal pressure 400bar</b>									
400	3/8"	SABS 4006	18	26.0	24.7	40	16	M 6 x 25	0.05
400	1/2"	SABS 4008	24	31.8	29.7	45	18	M 8 x 30	0.09
400	3/4"	SABS 4012	32	41.3	35.3	50	20	M 8 x 35	0.17
400	1"	SABS 4016	38	47.6	43.8	65	24	M 10 x 40	0.27
400	1 1/4"	SABS 4020	44	54.0	51.6	75	28	M 12 x 50	0.44
400	1 1/2"	SABS 4024	51	63.5	60.3	85	32	M 14 x 55	0.65
400	2"	SABS 4032	67	79.4	69.4	100	40	M 16 x 65	1.32
400	2 1/2"	SABS 4040	80	94.2	83.4	120	45	M 20 x 75	2.13
400	3"	SABS 4048	90	104.0	102.5	160	52	M 24 x 90	3.00
400	3 1/2"	SABS 4056	102	119.0	113.1	160	52	M 24 x 90	3.90
400	4"	SABS 4064	114	131.0	123.7	180	60	M 24 x 100	5.54